

MODULAR ABOVEDECK HYDRAULIC DRIVE

ROTARY SCREW AIR COMPRESSOR



80102-4H1

BOSS

The Difference is Revolutionary™

MODULAR ABOVEDECK HYDRAULIC DRIVE ROTARY SCREW SERIES

FEATURES

The Boss 80102-AHBI advanced design allows you the option to choose any CFM output up to 100 CFM with just one model. By simply adjusting hydraulic flow to the compressor the system will produce up to 100 CFM at 100 PSIG continuously. Now, when you need that extra boost, you have it.

The Boss 80102-AHBI modular unit is fully self-contained and compact. Mounted on its own frame the unit measures only 20" W x 30" H x 36" L. The compact design makes mounting possible even in tight spaces.

Installation is simple too. Just bolt the unit to the deck of your vehicle, connect your hydraulic system, wire to a 12V source and it's ready.

STANDARD EQUIPMENT

- Boss oil-flooded, rotary screw air end designed to produce up to 100 CFM @ 100 PSIG continuously.
- Two-year warranty air end.
- Self-contained separator element with easy access spin-on housing.
- Hydraulic motor directly coupled to geared air end.
- Integrated receiver tank with filler port and drain valve.
- Integrated compressor oil cooling package with automatic thermal sensing control to ensure proper operating temperatures.
- Replaceable spin-on compressor lubricant filter with safety bypass and 25-micron rating.
- 14 gauge powder coat aluminum rust proof enclosure.
- Two-stage, dry-type air intake filter with replaceable element and gravity evacuator.
- Instrumentation to include: hour meter, compressor lubricant temperature gauge and air pressure gauge.
- All components are frame mounted, plumbed and wired.
- Safety devices to include: minimum pressure device, compressor lubricant high temperature and high-pressure safety system, automatic blowdown device, high-pressure relief valve and necessary warning and information decals.
- Optional hydraulic system oil cooling packages available upon request. (recommended)

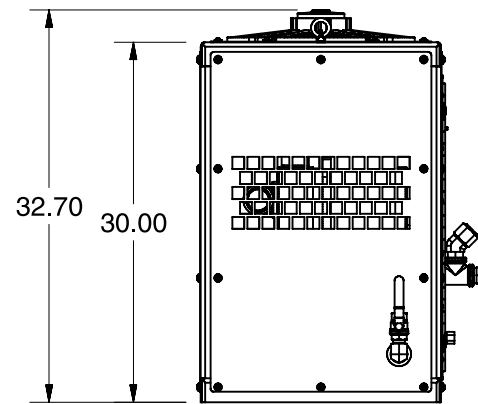
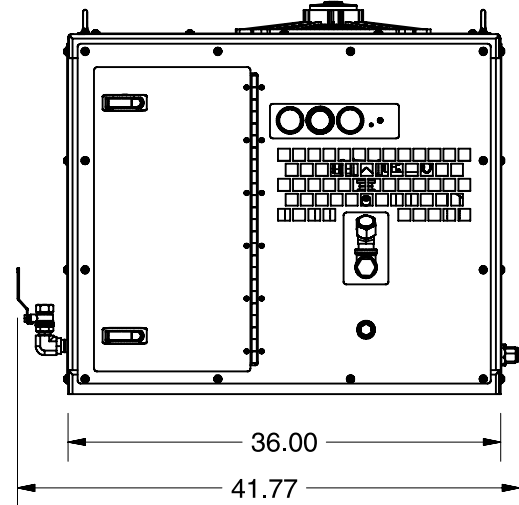

SPECIFICATIONS

80102-AHBI ROTARY SCREW AIR COMPRESSOR

Delivery @ 100 PSIG*	CFM	65	75	85	95	100
Input Speed RPM to Compressor	RPM	1945	2250	2500	2750	2900
Standard Motor "A" @ 2500 PSI	GPM	13.6	15.8	17.5	XX	XX
Optional Motor "B" @ 2000 PSI	GPM	17.8	20.6	22.8	25.1	26.5
Fluid Capacity	2.50 Gallons					
Compressor System	(Overall Dimensions)					
Compressor with canopy (standard)	20" W x 30" H x 36" L					
Weight (wet) with canopy	375 Pounds					

*150 and 200 PSIG options available. Consult Factory.
Specifications subject to change without notice.

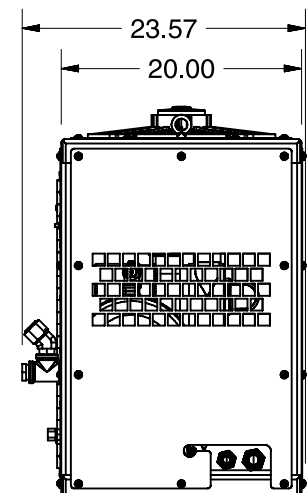

BOSS *The Difference is Revolutionary™*

BOSS INDUSTRIES, INC.

1761 Genesis Drive LaPorte, IN 46350
Voice: 219.324.7776 • 1.800.635.6587
Fax: 219.324.7470
Electronic: www.bossair.com • email: boss@bossair.com

DISTRIBUTED BY: