

**70 CFM ROTARY SCREW AIR COMPRESSOR**



**RY70**

BIG ENOUGH TO HANDLE THE TOUGHEST JOBS...

*SMALL ENOUGH TO BE VERSATILE AND LIGHT WEIGHT!*

**BOSS**

*The  
Difference is  
Revolutionary™*

## 70 CFM ROTARY SCREW AIR COMPRESSOR

# SPECIFICATIONS

### ENGINE

Type	Honda 4-Cycle, V-Twin Overhead Valve, Electric and Recoil Start
Model	GX20K1
Power (@3600 rpm)-Hp	20
Displacement-cu. In.	37.5
Bore-in. (mm), Stroke-in.	3.03, 2.60
Oil capacity (w/filter)-US qts	1.5
Battery Rating Volts	12v
CCA at 0 Degree F	275 cca
Fuel tank capacity	5.2 gal

### COMPRESSOR

Type	Oil Flooded Rotary Screw
Number of Stages	One
Rated Delivery	70 cfm
Rating Operating Pressure	100 psig*
Operating Pressure Range	80 - 115 psig
Ambient Operating Temp. Range	20 deg to +105 deg F
Oil Sump Capacity	1 gallons
Total System Volume	2.2 gallon
Air Service Connection	One 3/4" NPT
Type Cooling System	Oil to Air
Type Air Intake System	Single Stage Dry
Type of Control	0-100% Demand

### WEIGHT (DRY)

(Metrics in Parentheses)

Wheel Mounted	410 lbs (186 kg)
Dimensions	43" L x 31" W x 35" H

\*150 psig option available  
Specifications Subject to Change Without Notice

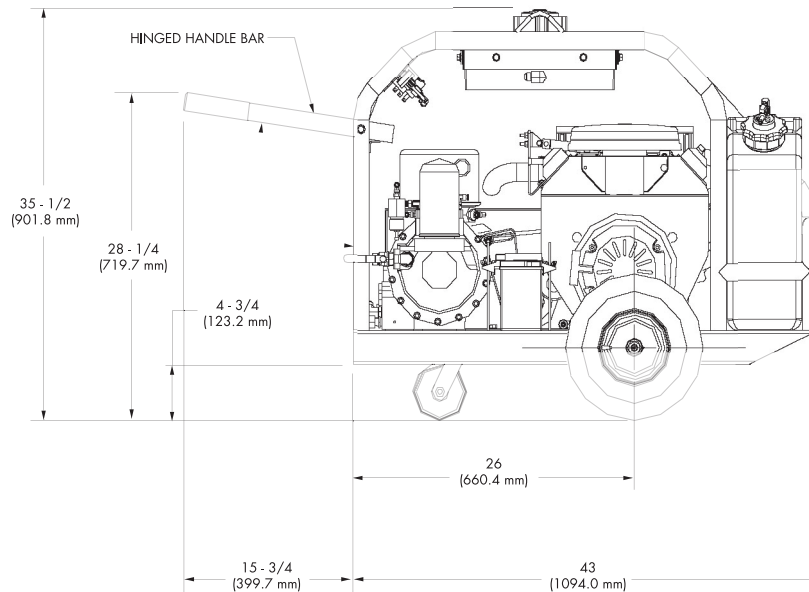
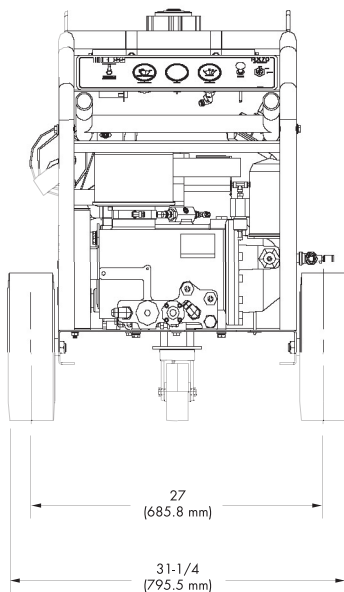

**DISTRIBUTED BY:**

### BOSS INDUSTRIES, INC.

1761 Genesis Drive LaPorte, IN 46350  
Voice: 219.324.7776 • 1.800.635.6587  
Fax: 219.324.7470  
Electronic: www.bossair.com • email: boss@bossair.com