

**BOSS SERIES 35
PTO AIR COMPRESSOR
OPERATORS, MAINTENANCE,
AND PARTS MANUAL**

OPERATORS AND PARTS MANUAL

TABLE OF CONTENTS

Operation & Maintenance Section

Compressor Specification	3
Safety	4-7
Compressor Terminology	8
Description of Components	9-12
Inspection, Lubrication, and Maintenance	13-19
Troubleshooting	20-21
Compressor Operation	22-23
Compressor Installation & Illustrations	24-36
Recommended Spare Parts	38
Service Questionnaire	39

Warranty Section

Warranty Information	40-48
----------------------------	-------

BOSS 35 - 175 ROTARY SCREW COMPRESSOR SPECIFICATIONS

**FAN EXHAUST, DO NOT BLOCK
OR HAVE RESTRICTION
WITHIN 12" OF CANOPY TOP**

OIL FILL ACCESS DOOR

SERVICE ACCESS DOOR

**HYD. RETURN
CONNECTION**

**AIR OUTLET
CONNECTION**

OIL DRAIN

**HYDRAULIC VALVE BLOCK
PRESS. CONNECTIONS**

20.50 18.74

33.37

18.00

**FAN INLET ALLOW 5"
CLEARANCE FOR
AMBIENT AIR**

	C.F.M. @ 100 PSIG			
	20	25	30	35
H.P.	5.5	6.4	7.5	9.0
COMPR. R.P.M.	3850	4650	5650	6400
HYD. MTR. R.P.M.	1925	2325	2825	3200
HYD. MTR. G.P.M.	7.5	9.0	11.0	12.4
HYD. MTR. P.S.I.	1436	1382	1337	1413
HYD. MTR. TORQUE	189"#	182"#	176"#	186"#

	C.F.M. @ 150 PSIG			
	20	25	30	35
H.P.	6.6	8.1	9.5	12.2
COMPR. R.P.M.	3900	4800	5750	6625
HYD. MTR. R.P.M.	1950	2400	2875	3312
HYD. MTR. G.P.M.	7.6	9.3	11.2	12.9
HYD. MTR. P.S.I.	1702	1694	1664	1853
HYD. MTR. TORQUE	224"#	223"#	219"#	244"#

	C.F.M. @ 175 PSIG			
	20	25	30	35
H.P.	7.8	9.3	11.5	13.0
COMPR. R.P.M.	4050	4950	5875	6800
HYD. MTR. R.P.M.	2025	2475	2937	3400
HYD. MTR. G.P.M.	7.9	9.6	11.4	13.2
HYD. MTR. P.S.I.	1937	1891	1967	1922
HYD. MTR. TORQUE	255"#	249"#	259"#	253"#

HYDRAULIC MOTOR FLOW AND PRESSURE ARE THEORETICAL AND WILL VARY WITH DIFFERENT HYDRAULIC DRIVE SYSTEMS

SAFETY

WARNING

ALL UNITS ARE SHIPPED WITH A DETAILED OPERATORS AND PARTS MANUAL. THIS MANUAL CONTAINS VITAL INFORMATION FOR THE SAFE USE AND EFFICIENT OPERATION OF THIS UNIT. CAREFULLY READ THE OPERATORS MANUAL BEFORE STARTING THE UNIT. FAILURE TO ADHERE TO THE INSTRUCTIONS COULD RESULT IN SERIOUS BODILY INJURY OR PROPERTY DAMAGE.

AIR COMPRESSOR SAFETY PRECAUTIONS

Safety is basically common sense. While there are standard safety rules, each situation has its own peculiarities that cannot always be covered by rules. Therefore with your experience and common sense, you are in a position to ensure your safety. Lack of attention to safety can result in: accidents, personal injury, reduction of efficiency and worst of all - Loss of Life. Watch for safety hazards. Correct them promptly. Use the following safety precautions as a general guide to safe operation:

Do not attempt to remove any compressor parts without first relieving the entire system of pressure.

Do not attempt to service any part while machine is operating.

DANGER

CHECK THE COMPRESSOR SUMP OIL LEVEL ONLY WHEN THE COMPRESSOR IS NOT OPERATING AND SYSTEM IS COMPLETELY RELIEVED OF PRESSURE. OPEN SERVICE VALVE TO ENSURE RELIEF OF SYSTEM AIR PRESSURE WHEN PERFORMING MAINTENANCE ON COMPRESSOR AIR/OIL SYSTEM. FAILURE TO COMPLY WITH THIS WARNING MAY CAUSE DAMAGE TO PROPERTY AND SERIOUS BODILY HARM.

Do not operate the compressor at pressure or speed in excess of its rating as indicated in "Compressor Specifications".

Periodically check all safety devices for proper operation.

Do not play with compressed air. Pressurized air can cause serious injury to personnel.

SAFETY

Do not install a shut-off valve between the compressor and compressor oil sump.

DANGER

DO NOT USE BOSS COMPRESSOR SYSTEMS TO PROVIDE BREATHING AIR. SUCH USAGE, WHETHER SUPPLIED IMMEDIATELY FROM THE COMPRESSOR SOURCE, OR SUPPLIED TO BREATHING TANKS FOR SUBSEQUENT USE, CAN CAUSE SERIOUS BODILY INJURY.

BOSS DISCLAIMS ANY AND ALL LIABILITIES FOR DAMAGE FOR LOSS DUE TO PERSONAL INJURIES, INCLUDING DEATH, AND/OR PROPERTY DAMAGE INCLUDING CONSEQUENTIAL DAMAGES ARISING OUT OF ANY BOSS COMPRESSORS USED TO SUPPLY BREATHING AIR.

Do not disconnect or bypass safety circuit system.

Do not install safety devices other than authorized BOSS replacement devices.

Close all openings and replace all covers and guards before operating compressor unit.

Tools, rags, or loose parts must not be left on the compressor anywhere near drive belts and pulleys.

Do not use flammable solvents for cleaning parts.

Keep combustibles out of and away from the Compressor and any associated enclosures.

The owner, lessor, or operator of the Compressor are hereby notified and forewarned that any failure to observe these safety precautions may result in damage or injury.

BOSS expressly disclaims responsibility or liability for any injury or damage caused by failure to observe these specified precautions or by failure to exercise that ordinary caution and due care required when operating or handling the Compressor, even though not expressly specified above.

SAFETY

A compliment of warning decals is supplied with each unit. These decals must be affixed to the vehicle after it has been painted, trimmed, and undercoated, etc., and prior to being put into service. The decals shall be placed so as to be clearly visible to the user and service personnel.

! DANGER

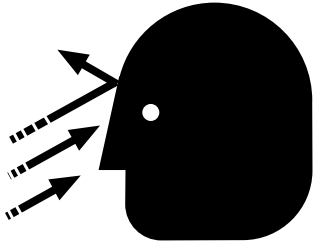

HOT OIL UNDER PRESSURE!
Will cause **SEVERE PERSONAL INJURY OR DEATH**. Do not remove valves, caps, plugs or piping when compressor is running or pressurized. Shut down compressor and relieve system of all pressure before removing valves, caps, plugs or piping

300038

! DANGER



Discharge air used for breathing will cause severe injury or death consult filtration specialist for additional filtration and treatment equipment to meet occupational safety and health administration standards

300040

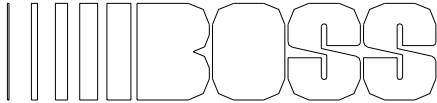
	
BOSS INDUSTRIES, INC.	
720 BOYD BLVD. La PORTE, IN 46350	
MODEL NO.	_____
SERIAL NO.	_____
INPUT R.P.M.	_____

SAFETY

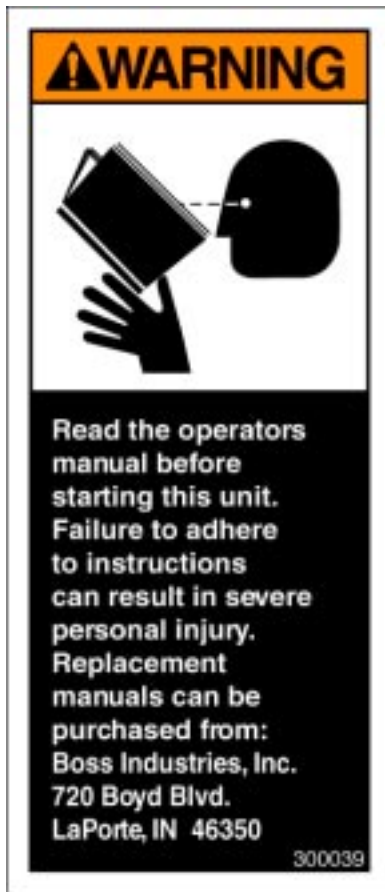

COMPRESSOR FLUID FILL
USE BOSS ROTARY SCREW COMPRESSOR
FLUID ONLY.

1. CHECK FLUID LEVEL DAILY WITH TRUCK OFF AND PARKED ON LEVEL GROUND.
2. MAXIMUM FLUID LEVEL IS AT THE BOTTOM OF FILL PLUG CASTING THREADS.
3. MINIMUM FLUID LEVEL IS 1/2" BELOW BOTTOM OF FILL PLUG CASTING THREADS(1/2" BELOW MAX).

302694

DANGER

DRIVE COUPLING IN
ROTATION DURING
COMPRESSOR OPERATION.
DO NOT RUN COMPRESSOR
WITH CANOPY OFF.

301442

COMPRESSOR TERMINOLOGY

AIR/OIL COALESCER - Performs second stage separation of oil from compressed air feeding air tools. Sometimes referred to as the separator element.

CFM - Refers to the volume of compressed air being produced expressed as cubic feet of air per minute.

OIL SUMP - The first stage of oil separation from compressed air. Also serves as reservoir area for compressor lubricant and sometimes referred to as the receiver tank.

PSI - Refers to the operating pressure the system is set up at, expressed as pounds per square inch.

SAFETY VALVE - A valve located on the oil sump which opens in case of excessive pressure. Sometimes referred to as the pop-off or pressure relief valve.

SHUTDOWN SWITCH - Works in conjunction with a temperature switch, sending a signal to stop the compressor power source in cases of high temperature.

SIDE MOUNT PTO - Power take off gearbox that bolts to the side of the transmission. The PTO input gear meshes with one of the gears in the vehicle's transmission. The rotation developed by the engine drives the transmission which turns the PTO gear box and powers the hydraulic pump.

HYDRAULIC MOTOR - Motor that drives compressor through a belt driven system.

DESCRIPTION OF COMPONENTS

COMPRESSOR ASSEMBLY

The BOSS Series 35 PTO compressor assembly is a positive displacement, oil flooded, rotary screw type unit employing one stage of compression to achieve the desired pressure. Components include a housing (stator) with integral oil sump, two screws (rotors), bearings, and bearing supports. Power from the hydraulic motor is transferred through a belt drive system to the male rotor, which in turn drives the female rotor.

PRINCIPLES OF OPERATION

In operation, two helical grooved rotors mesh to compress air. Inlet air is trapped as the male lobes roll down the female grooves, pushing trapped air along, compressing it until it reaches the discharge port in the end of the stator and delivers smooth-flowing, pulse-free air to the receiver.

During the compression cycle, oil is injected into the compressor and serves these purposes:

1. Lubricates the rotating parts and bearings.
2. Serves as a cooling agent for the compressed air.
3. Seals the running clearances.

LUBRICATION SYSTEM

Oil from the integral sump is directed through the thermal bypass valve. The bypass valve directs oil through the oil cooler during hot operation then back to the oil filter built into the compressor housing. During cold operation oil is sent directly back to the filter compressor port.

OIL SUMP

Compressed, oil-laden air enters the sump from the compressor. As the oil-laden air enters the sump, most of the oil is separated from the air. The oil accumulates at the bottom of the sump for recirculation. However, some small droplets of oil remain suspended in the air and are passed on to the coalescer.

DESCRIPTION OF COMPONENTS

SAFETY VALVE

The pop safety valve is set at 200 PSI and is located at the top of the integral air/oil sump. This valve acts as a backup to protect the system from excessive pressure that might result from a malfunction.

AIR/OIL COALESCER

The coalescer is self-contained within a spin-on housing and is mounted to the discharge housing. When air is demanded at the service line, it passes through the coalescer, which efficiently provides the final stage of oil separation.

MINIMUM PRESSURE VALVE

The minimum pressure valve is located directly under the coalescing element and serves to maintain a minimum discharge pressure of 80 PSIG in operation, which is required to assure adequate compressor lubrication pressure..

OIL FILTER

The compressor oil filter is the full-flow replaceable element type and has a safety bypass built into it.

COMPRESSOR COOLING SYSTEM

The compressor cooling system consists of an oil cooler, electric fan motor, and fan. The fan/cooler package is self-contained in an aerodynamically designed housing.

An automated thermostatic control system maintains a temperature check of the lubricant. A continuous running fan/cooler package forces ambient air over the cooler fins ensuring a proper operating temperature.

ELECTRICAL AND SAFETY CIRCUIT SYSTEM

The Series 35 unit is supplied with an electric fan motor and a high temperature shutdown switch. The high temperature shutdown switch will shut unit down in cases of high discharge temperature. Power supply harness is included and only a 12 VDC power supply and ground is needed for electrical connections.

DESCRIPTION OF COMPONENTS

AUTOMATIC BLOW DOWN VALVE

A blow down valve is located at the downstream side of the regulator manifold and will automatically bleed the sump to zero pressure when the compressor is disengaged.

Blow down time interval takes between 30 to 60 seconds. Compressor reengagement can not occur until blow down cycle is complete.

CONTROL SYSTEM

The prime component of the compressor control system includes the compressor inlet valve. The control system is designed to match air supply to air demand and to prevent excessive discharge pressure when compressor has no demand. Control of air delivery is accomplished by the inlet valve regulation.

DISCHARGE PRESSURE REGULATOR VALVE

This valve, located on the compressor unit is used to set the desired discharge pressure within the operating pressure range. Turning the regulator screw clockwise increases the working pressure, a counterclockwise movement of the screw reduces the working pressure. The system has a maximum operating pressure of 175 lbs.

NOTE: Most air tool operating pressure range is between 90 and 125 psi. Operating above the tools recommended pressures will decrease the life of the tool. Higher operating pressure can also over torque nut and bolts fatiguing the fastener and mating parts. Strictly adhere to tool operating pressures and torque standards set forth by the tool manufacturer and the specifications of the equipment that work is being performed on.

INLET VALVE

The compressor inlet valve is a piston operated disc valve that has a dual function of regulating the inlet opening to control capacity and serving as a check valve at shutdown.

DESCRIPTION OF COMPONENTS

CONTROL SYSTEM OPERATION

The following discussion explains the operation of the control system from a condition of “no load” to a condition of “full capacity” at working pressure. For the working pressure range of your machine, refer to applicable data in “Specifications”.

The pressure regulator, mounted on the regulator manifold, operates as follows:

1. As the demand for air decreases, the receiver pressure rises. When this pressure exceeds the set point of the pressure regulator, the regulator opens sending a secondary pressure signal to the inlet valve. The poppet valve moves towards the valve inlet against the force of the modulating spring inside the valve. This regulates the opening area of the inlet valve.
2. If the air demand goes to zero, (service valve closed or air deadheaded at tool) the inlet valve will close completely.
3. As the demand for air increases, the secondary pressure signal to the inlet valve is removed and the inlet valve poppet modulates to full open.

INSPECTION, LUBRICATION, AND MAINTENANCE

This section contains instructions for performing the inspection, lubrication, and maintenance procedures required to maintain the compressor in proper operating condition. The importance of performing the maintenance described herein cannot be over emphasized.

The periodic maintenance procedures to be performed on the equipment covered by this manual are listed below. It should be understood that the intervals between inspections specified are maximum interval. More frequent inspections should be made if the unit is operating in a dusty environment, in high ambient temperature, or in other unusual conditions. A planned program of periodic inspection and maintenance will help avoid premature failure and costly repairs. Daily visual inspections should become a routine.

The LUBRICATION AND MAINTENANCE CHART lists serviceable items on this compressor package. The items are listed according to their frequency of maintenance, followed by those items which need only “As Required” maintenance.

The maintenance time intervals are expressed in hours. The hourmeter shows the total number of hours your compressor has run. Use the total number of hours run for determining your maintenance schedules. Perform the maintenance at multiple intervals of the hours shown. For example, when 100 hours has elapsed all items listed under “EVERY 10 HOURS” should be serviced for the tenth time, and all items under “EVERY 50 HOURS” should be serviced for the second time, and so on.

DANGER

COMPRESSOR MUST BE SHUT DOWN AND COMPLETELY RELIEVED OF PRESSURE PRIOR TO CHECKING FLUID LEVELS. OPEN SERVICE VALVE TO ENSURE RELIEF OF SYSTEM AIR PRESSURE. FAILURE TO COMPLY WITH THIS WARNING MAY CAUSE DAMAGE TO PROPERTY AND SERIOUS BODILY HARM.

LUBRICATION AND MAINTENANCE CHART

INTERVAL	ACTION
PERIODICALLY DURING OPERATION	<ol style="list-style-type: none"> 1. Note any change from the NORMAL reading and determine the cause. Have necessary repairs made. (Note: "NORMAL" is the usual operating conditions on a day to day basis.)
EVERY 10 HOURS OR DAILY	<ol style="list-style-type: none"> 1. Check compressor oil level. 2. Check air filter. Pressure drop indicator while compressor is operating. 3. Check for oil and leaks. 4. Check safety circuit switches. <p>NOTE: After first 10 hours of operation check belt tension and adjust.</p>
EVERY 25 HOURS OR MONTHLY	<ol style="list-style-type: none"> 1. Drain water from compressor oil.
EVERY 100 HOURS	<ol style="list-style-type: none"> 1. Check belt tension.
EVERY 500 HOURS OR 6 MONTHS	<ol style="list-style-type: none"> 1. Change compressor oil and oil filter. 2. Check compressor shaft seal for leakage. 3. Check air filter piping, fitting, and clamps. 4. Check compressor supports. 5. Install new air filter element. (Shorter interval may be necessary under dusty conditions.) 6. Check sump safety valve. 7. Check belt tension.
EVERY 1000 HOURS	<ol style="list-style-type: none"> 1. Change coalescing element.
PERIODICALLY OR AS REQUIRED	<ol style="list-style-type: none"> 1. Inspect and clean air filter element. 2. Inspect and replace spin-on coalescer element if necessary. 3. Inspect and clean oil cooler fins.

LUBRICANT RECOMMENDATIONS

WARNING

IT IS IMPORTANT THAT THE COMPRESSOR OIL BE OF A RECOMMENDED TYPE AND THAT THIS OIL AS WELL AS THE AIR FILTER, OIL FILTER, AND COALESCER ELEMENTS BE INSPECTED AND REPLACED AS STATED IN THIS MANUAL.

THE COMBINATION OF A COALESCER ELEMENT LOADED WITH DIRT AND OXIDIZED OIL PRODUCTS TOGETHER WITH INCREASED AIR VELOCITY AS A RESULT OF THIS CLOGGED CONDITION MAY PRODUCE A CRITICAL POINT WHILE THE MACHINE IS IN OPERATION WHERE IGNITION CAN TAKE PLACE AND COULD CAUSE A FIRE IN THE OIL SUMP.

FAILURE TO COMPLY WITH THIS WARNING MAY CAUSE DAMAGE TO PROPERTY AND SERIOUS BODILY HARM.

The following are general characteristics for a rotary screw lubricant. Due to the impossibility of establishing limits on all physical and chemical properties of lubricants which can affect their performance in the compressor over a broad range of environmental influences, the responsibility for recommending and consistently furnishing a suitable heavy duty lubricant must rest with the individual supplier if they choose not to use the recommended BOSS INDUSTRIES rotary screw lubricant. The lubricant supplier's recommendation must, therefore, be based upon not only the following general characteristics, but also upon his own knowledge of the suitability of the recommended lubricant in PTO helical screw type air compressors operating in the particular environment involved.

CAUTION

MIXING DIFFERENT TYPES OR BRANDS OF LUBRICANTS IS NOT RECOMMENDED DUE TO THE POSSIBILITY OF A DILUTION OF THE ADDITIVES OR A REACTION BETWEEN ADDITIVES OF DIFFERENT TYPES.

LUBRICANT RECOMMENDATIONS

LUBRICANT CHARACTERISTICS

1. Flash point 400°F minimum.
2. Pour point -40°F.
3. Contains rust and corrosion inhibitors.
4. Contains foam suppressors.
5. Contains oxidation stabilizer.

NOTE

DUE TO ENVIRONMENTAL FACTORS THE USEFUL LIFE OF ALL “EXTENDED LIFE” LUBRICANTS MAY BE SHORTER THAN QUOTED BY THE LUBRICANT SUPPLIER. BOSS INDUSTRIES ENCOURAGES THE USER TO CLOSELY MONITOR THE LUBRICANT CONDITION AND TO PARTICIPATE IN AN OIL ANALYSIS PROGRAM WITH THE SUPPLIER.

NOTE

NO LUBRICANT, HOWEVER GOOD AND/OR EXPENSIVE, CAN REPLACE PROPER MAINTENANCE AND ATTENTION. SELECT AND USE IT WISELY.

COMPRESSOR OIL SUMP FILL, LEVEL, AND DRAIN

Before adding or changing compressor oil make sure that the sump is completely relieved of pressure. Oil is added at the fill cap on the side of the receiver/sump. A drain plug is provided at the bottom of the sump. The proper oil level, when unit is shut down and has had time to settle, is at the midpoint of the oil sightglass. The truck must be level when checking the oil. **DO NOT OVERFILL.** The oil sump capacity is given in “Compressor Specifications”.

DANGER

DO NOT ATTEMPT TO DRAIN CONDENSATE, REMOVE THE OIL LEVEL FILL PLUG, OR BREAK ANY CONNECTION IN THE AIR OR OIL SYSTEM WITHOUT SHUTTING OFF COMPRESSOR AND MANUALLY RELIEVING PRESSURE FROM THE SUMP. FAILURE TO COMPLY WITH THIS WARNING MAY CAUSE DAMAGE TO PROPERTY AND SERIOUS BODILY HARM.

MAINTENANCE

If some of the maintenance intervals in the schedule outlined in this manual seem to be rather short, it should be considered that one hour's operation of a compressor is equal to about 40 road miles on an engine. Thus, eight hours operation is equal to 320 road miles, 250 hours is equal to 10,000 road miles, etc.

AIR INTAKE FILTER

The air intake filter is a heavy-duty two-stage dry type high efficiency filter designed to protect the compressor from dust and foreign objects.

Frequency of maintenance of the filter depends on dust conditions at the operating site. The filter element must be serviced when clogged (maximum pressure drop for proper operation is 15" H₂O). (If so equipped.)

AIR/OIL COALESCER

The air/oil coalescer employs an element permanently housed within a spin-on canister. This is a single piece unit that requires replacement when it fails to remove the oil from the discharge air. Dirty oil clogs the element and increases the pressure drop across it.

To replace element proceed as follows:

1. Shutdown compressor and wait for complete blow down (zero pressure).
2. Turn element counterclockwise for removal.
3. Check new rubber seal in head and supply a film of fluid directly to seal.
4. Rotate element clockwise by hand until element contacts seal.
5. Rotate element approximately one more turn clockwise with band wrench near the top of element.
6. Run system and check for leaks.

WARNING

DO NOT SUBSTITUTE ELEMENT. USE ONLY A GENUINE BOSS REPLACEMENT ELEMENT. THIS ELEMENT IS RATED AT 200 PSI WORKING PRESSURE. USE OF ANY OTHER ELEMENT MAY BE HAZARDOUS AND COULD IMPAIR THE PERFORMANCE AND RELIABILITY OF THE COMPRESSOR, POSSIBLY VOIDING THE WARRANTY AND/OR RESULTING IN DAMAGE TO PROPERTY AND SERIOUS BODILY HARM.

MAINTENANCE

OIL FILTER

The compressor oil filter is a spin-on, throw away type.

To replace filter proceed as follows:

1. Make sure system pressure is relieved.
2. Remove filter by unscrewing from filter head (turn counterclockwise by hand) and discard.
3. Install a new filter by applying a little oil to the seal and then screw the filter on by hand (turning it clockwise until hand tight, plus one - third turn). Do not use tools to tighten the filter.
4. Check for leaks in operation.
5. Dispose of oil filter in accordance with all local laws and regulations.

WARNING

DO NOT SUBSTITUTE ELEMENT. USE ONLY A GENUINE BOSS REPLACEMENT ELEMENT. THIS ELEMENT IS RATED AT 200 PSI WORKING PRESSURE. USE OF ANY OTHER ELEMENT MAY BE HAZARDOUS AND COULD IMPAIR THE PERFORMANCE AND RELIABILITY OF THE COMPRESSOR, POSSIBLY VOIDING THE WARRANTY AND/OR RESULTING IN DAMAGE TO PROPERTY AND SERIOUS BODILY HARM.

OIL COOLER

In extreme cases the interior of the oil cooler should be cleaned when the pressure drop across it at full flow exceeds 25 PSI. The following procedure has been recommended by the vendor who supplies the cooler:

1. Remove cooler.
2. Circulate a suitable solvent to dissolve and remove varnish and sludge.
3. Flush generously with oil.
4. After cooler is reinstalled and compressor is filled with fresh oil, change compressor oil after 50 hours of normal operation.

MAINTENANCE

COMPRESSOR SHAFT OIL SEAL

To remove the oil seal first remove the belts and pulley. Then unbolt seal cover plate and pull seal out of housing. Reverse procedure to install.

NOTE

THE SEAL COVER IS INSTALLED USING AN O-RING GASKET. CARE SHOULD BE TAKEN TO NOT PINCH THE O-RING OUT OF ITS GROOVE UPON REINSTALLATION.

PTO

The PTO should be serviced in accordance with the PTO manual. The SAE side-mount type of PTO is lubricated by the transmission oil and thus requires little maintenance. It is strongly recommended that you periodically torque the fasteners in accordance with the PTO manual.

COMPRESSOR DRIVE BELTS

The 2 belt arrangement is sized for an average life of 1000 hours. This time frame can be increased or decreased depending on the end users periodic maintenance schedule. Drive belt tension should be checked for adjustment after the first 10 hours of operation and checked for adjustment every 100 hours there after. Belt deflection is to be checked at midpoint between both pulleys on one belt at a time. Single belt deflection is to be 1/8" at 3.5 lbs. Minimum to 5.0 lbs. Maximum.

BELT TENSION - Belt tension is accomplished as follows:

- Loosen 1/2" bolt that attaches the hydraulic motor mounting plate to the compressor.
- Loosen 3/8" jam nut on the turn buckle assembly.
- Loosen 3/8" nuts at the top and bottom eyebolts.
- Rotate turnbuckle nut clockwise to increase belt tension and counterclockwise to decrease belt tension.

NOTE: Over-tensing belts can damage compressor and drive motor. When tensing belts all hardware should be broken loose only to the point in which the drive pulley can pivot when rotating the turnbuckle nut.

TROUBLESHOOTING

This section contains instructions for troubleshooting the equipment following a malfunction.

The troubleshooting procedures to be performed on the equipment are listed below. Each symptom of trouble for a component or system is followed by a list of probable causes of the trouble and suggested procedures to be followed to identify the cause.

In general, the procedures listed should be performed in the order in which they are listed, although the order may be varied if the need is indicated by conditions under which the trouble occurred. In any event, the procedures which can be performed in the least amount of time and with the least amount of removal or disassembly of parts, should be performed first.

UNPLANNED SHUTDOWN

When the operation of the machine has been interrupted by an unexplained shutdown, check the following:

1. Check the fuel level and truck dash gauges and indications for possible engine problems.
2. Check the compressor high discharge temperature switch.
3. Check oil cooler for dirt, slush, ice on the fins, or any other obstructions to cooling the airflow.
4. Make a thorough external check for any cause of shutdown such as broken hose.
5. Check to determine if the compressor oil is at proper level.

IMPROPER DISCHARGE PRESSURE

1. If discharge pressure is too low, check the following:
 - a. Too much air demand. (Air tools require more air than what the compressor can produce.)
 - b. Service valve wide open to atmosphere.
 - c. Leaks in service line.
 - d. Restricted compressor inlet air filter.
 - e. Faulty control system operation (i.e. regulator is sending a signal to close inlet valve at all times.)
2. If discharge pressure is too high or safety valve blows, check the following:
 - a. Faulty discharge pressure gauge.
 - b. Coalescer plugged up.
 - c. Faulty safety valve.
 - d. Faulty regulator (regulator air pressure signal is not getting to inlet valve).

TROUBLESHOOTING

SUMP PRESSURE DOES NOT BLOW DOWN

If after the compressor is shutdown, pressure does not automatically blow down, check for:

1. Automatic blow down valve may be inoperative at regulator manifold.
2. Blockage in air line from side of inlet valve to blow down valve.
3. Muffler at blow down clogged.

OIL CONSUMPTION

Abnormal oil consumption or oil in service line, check for the following:

1. Over filling of oil sump.
2. Leaking oil lines or oil cooler.
3. Plugged oil return line: check sightglass.
4. Defective coalescer element.
5. Compressor shaft seal leakage.
6. Discharge pressure below 65 PSI or above 175 PSI.

COALESCER PLUGGING

If the coalescer element has to be replaced frequently because it is plugging up, it is an indication that foreign material may be entering the compressor inlet or the compressor oil is breaking down.

Compressor oil can break down prematurely for a number of reasons.

- (1) Extreme operating temperature.
- (2) Negligence in draining condensate from oil sump.
- (3) Using the improper type of oil.
- (4) Dirty oil.

The complete air inlet system should be checked for leaks.

HIGH COMPRESSOR DISCHARGE TEMPERATURE

1. Check compressor oil level. Add oil if required (see Section for oil specifications).
2. Check thermal valve operation.
3. Clean outside of oil cooler.
4. Clean oil system (cooler) internally.

COMPRESSOR OPERATION

Before starting the compressor, read this section thoroughly. Familiarize yourself with the controls and indicators, their purpose, location, and use.

CONTROL OR INDICATOR	PURPOSE
FLUID LEVEL SIGHTGLASS	Indicates fluid level in the sump. Proper level should be at bottom of fill plug casting threads. Check this level when the compressor is disengaged and the vehicle is parked on level ground.
PRESSURE RELIEF VALVE	Vents sump pressure to the atmosphere if the pressure inside the sump exceeds 200 PSI.
COMPRESSOR INLET CONTROL VALVE	Regulates the amount of air intake in accordance with the amount of compressed air being used. Isolates fluid in compressor unit on shutdown.
PRESSURE REGULATING VALVE	Senses air pressure from sump to provide automatic regulation of the compressor inlet control valve.
BLOW DOWN VALVE	The blow down valve vents the sump pressure to the atmosphere at shutdown.
MINIMUM PRESSURE VALVE	Restricts air flow to balance sump and service air pressure. Assures a minimum of 80 PSI to maintain compressor lubrication.

COMPRESSOR OPERATION

OPERATING CONDITIONS

The following conditions should exist for maximum performance of the compressor. The truck should be as close to level as possible when operating. The compressor will operate on a 15 degree sideward and lengthwise tilt without any adverse problems. Fluid carry over and/or oil starvation may occur if operated beyond this tilt.

NOTE

IF THE COMPRESSOR IS BEING USED TO POWER SANDBLASTING EQUIPMENT, OR AN AIR STORAGE TANK, USE A CHECK VALVE DIRECTLY AFTER THE MINIMUM PRESSURE VALVE TO PREVENT BACKFLOW INTO THE SUMP. THIS CHECK VALVE SHOULD HAVE A MAXIMUM PRESSURE DROP RATING OF 2 PSIG (13.78kPa) OPERATING AND A CAPACITY RATING EQUAL TO THE COMPRESSOR.

NOTE

THE COMPRESSOR SERVICE VALVE SHOULD BE RELOCATED TO THE HOSE REEL INLET OR BE THE CUSTOMERS AIR CONNECTION PORT WHEN A HOSE REEL IS NOT USED. TYPICAL PLUMBING FROM CANOPY AIR OUTLET PORT:

- 1. CHECK VALVE.**
- 2. AIR TANK (WHEN USED).**
- 3. SERVICE VALVE.**
- 4. MOISTURE TRAP/GAUGE/OILER COMBINATION (WHEN USED).**
- 5. HOSE REEL (WHEN USED).**

COMPRESSOR INSTALLATION

1. Prepare the mounting location of the compressor by drilling four (4) holes 7/16" diameter as shown in the following installation diagram.
2. If rubber isolators are to be used position these over drilled mounting holes.
3. Bottom side of compressor uses 3/8"-16 weld nuts. Mounting bolts are to go thru the mounting surface to the weld nuts with 3/8" of the bolt extending beyond the top side of the weld nut.
4. Tighten mounting bolts.

ELECTRICAL & HYDRAULIC AIR CONNECTIONS

The hydraulic connections for pump feed and return are made at the valve block (see Installation Diagram) pressure feed line should be a minimum 3/4" hose rated for 3000 PSI. The pressure feed port size is -12 SAE o-ring connection. The minimum line back to tank should be 1" hose rated at 1000 PSI. The return port size is 3/4" NPT.

The air connection port is 1/2" NPT.

See diagram for Electrical Connections.

COMPRESSOR MOUNTING INSTALLATION

RED 12 GA. WIRE MAIN POWER FEED TO PACKAGE. REQUIRES 25 AMP CIRCUIT BREAKER. BLACK 12 GA. SYSTEM GROUND TO TRUCK FRAME.

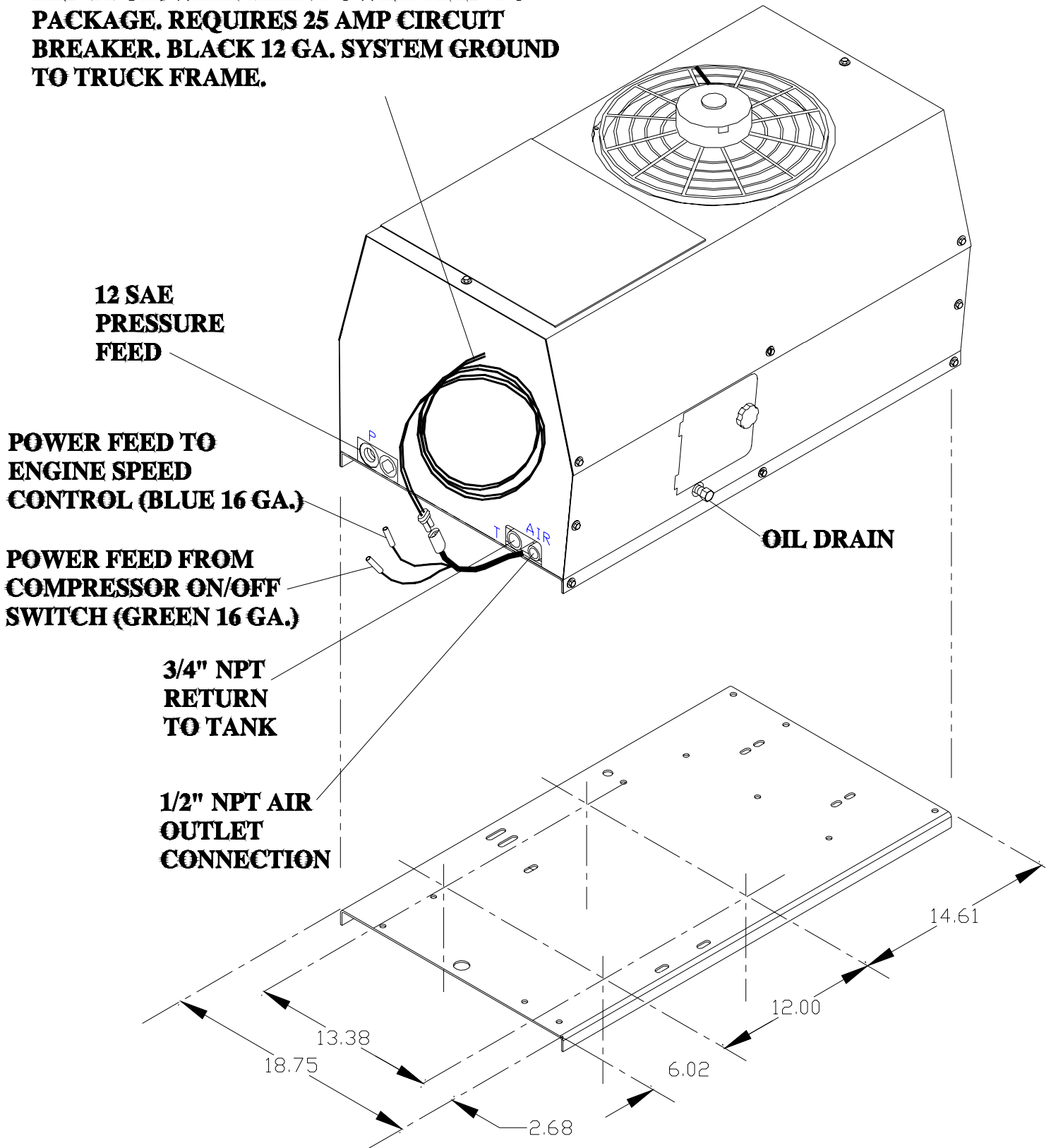

OIL COOLING SYSTEM

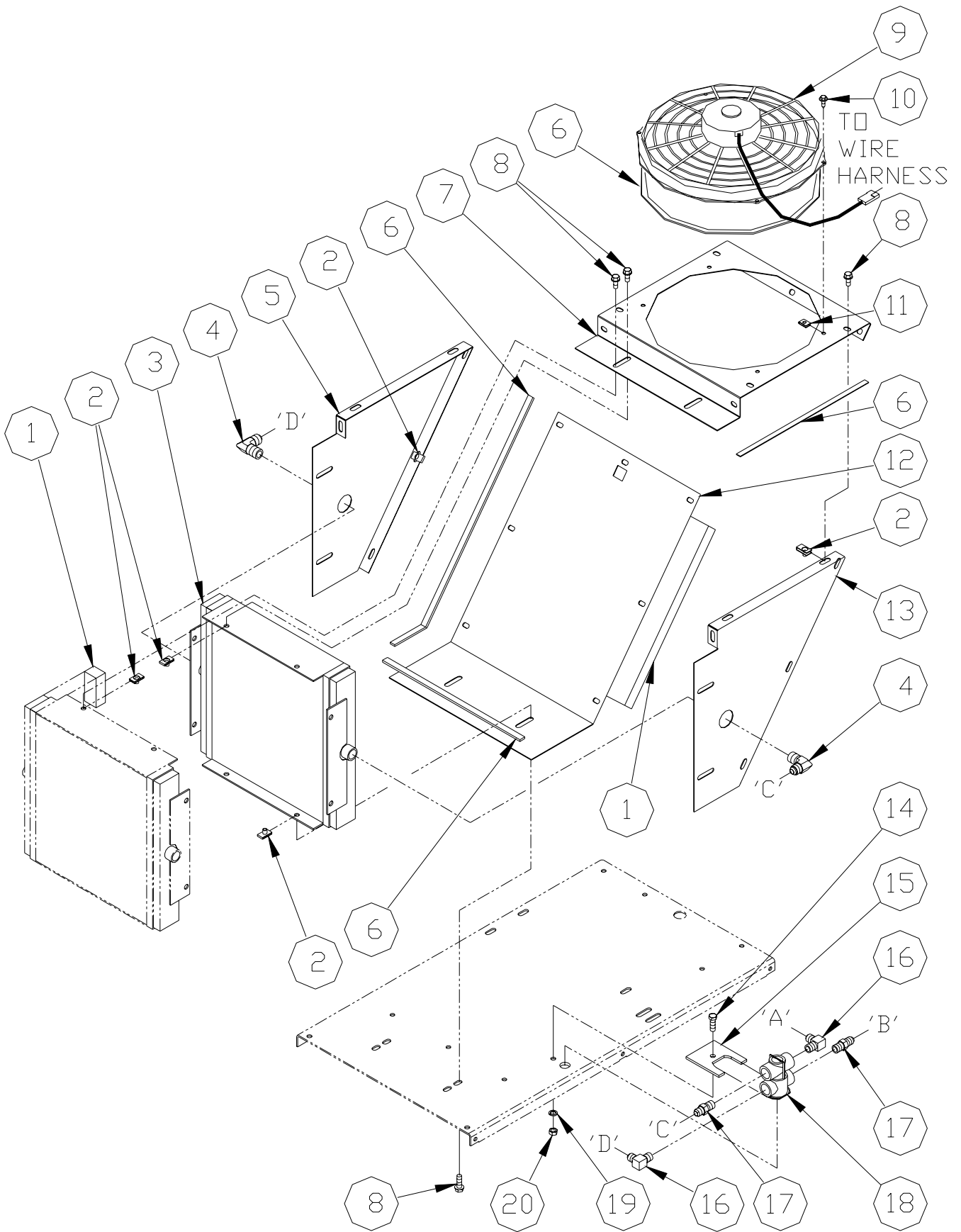

OIL COOLING SYSTEM

ITEM	PART NUMBER	DESCRIPTION	QTY.
1	301380	INSULATION, 1" POLY	1
2	961505-140	RETAINER, NUT 5/16	28
3	300836	COOLER, OIL	1
4	960208-050	ELBOW, 1/2" NPT X 1/2 JIC	2
5	3013401	DUCT, SIDE OIL COOLER - LEFT	1
6	300444	TAPE, 1/16" X 3/4" CELL	15
7	301339	DUCT, TOP OIL COOLER	1
8	929705-100	BOLT, WHIZ 5/16 x 1"	28
9	301378	FAN ASSY, 13 W/GRILL	1
10	974604-088	BOLT, HEX 1/4-20 X 7/8"	4
11	961504-090	RETAINER	4
12	301338	DUCT, BOTTOM OIL COOLER	1
13	301340R	DUCT, SIDE OIL COOLER - RIGHT	1
14	929806-100	BOLT, HEX 3/8" X 1"	1
15	301395	BRACKET, THERMAL VALVE MTG	1
16	960208-038	ELBOW, 3/8" NPT X 1/2" JIC	2
17	960108-038	CONNECTOR, 3/8" NPT X 1/2" JIC	2
18	301261	VALVE, THERMAL 3/8"	1
19	937806-094	WASHER, LOCK 3/8"	1
20	926006-337	NUT, HEX 3/8"	1

'A' OIL FROM SUMP TO THERMAL VALVE (HOSE ASSY. 975508-014)

'B' OIL FROM THERMAL VALVE TO COMPRESSOR OIL INLET (HOSE ASSY. 975408-021)

'C' OIL FROM THERMAL VALVE TO COOLER (HOSE ASSY. 975408-012)

'D' OIL FROM COOLER TO THERMAL VALVE (HOSE ASSY. 975408-019)

SERVICE VALVE LINE FROM COMPRESSOR TO 1/2" CUSTOMER CONNECTION
(HOSE ASSY. 975408-017)

CANOPY AND INSULATION

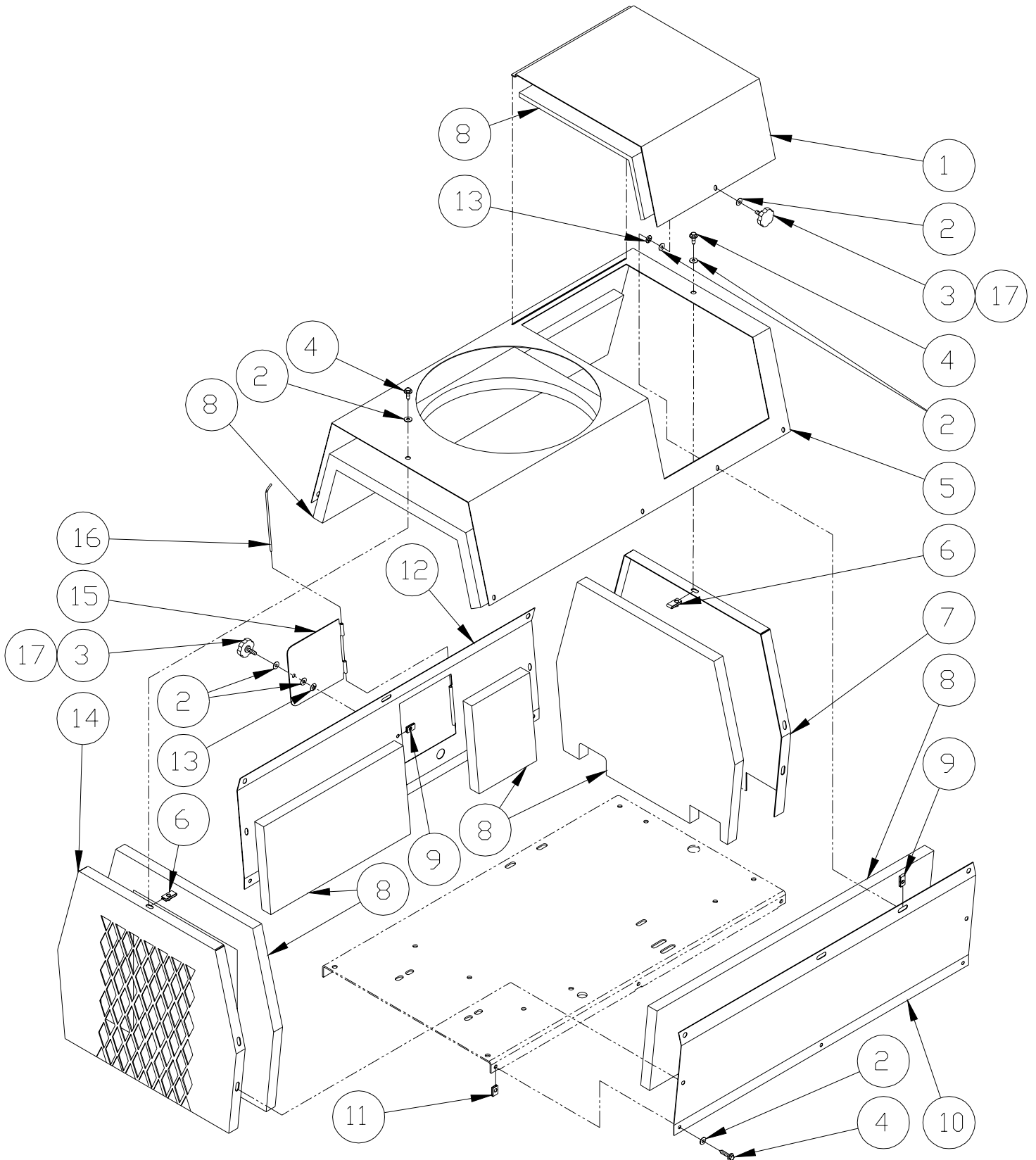

REVISED 03/16/99-MB

M10015

CANOPY AND INSULATION

ITEM	PART NUMBER	DESCRIPTION	QTY.
1	301365	DOOR, ACCESS TOP	1
2	300956	WASHER, NYLON	22
3	301373-025	KNOB	2
4	974604-088	BOLT, HEX 1/4"-20 X 7/8"	18
5	301357	CANOPY, TOP COVER	1
6	961504-090	NUT, RETAINER 1/4"	18
7	301342	PANEL, END	1
8	301380	INSULATION, 1" POLY	15
9	960904-090	NUT, RETAINER	8
10	301336	PANEL SIDE	1
11	975804-012	NUT, RETAINER	6
12	301356	PANEL, SIDE OIL FILL	1
13	943415-250	RETAINER, KNOB TO PANEL	2
14	301341	PANEL, END OIL COOLER	1
15	301368	DOOR, OIL FILL	1
16	301379-005	PIN, DOOR HINGE 1/8" DIA X 5 3/16	1
17	930004-075	BOLT, SOCKET HEAD 1/4" X 3/4"	2

ELECTRICAL HARNESS AND ROUTING

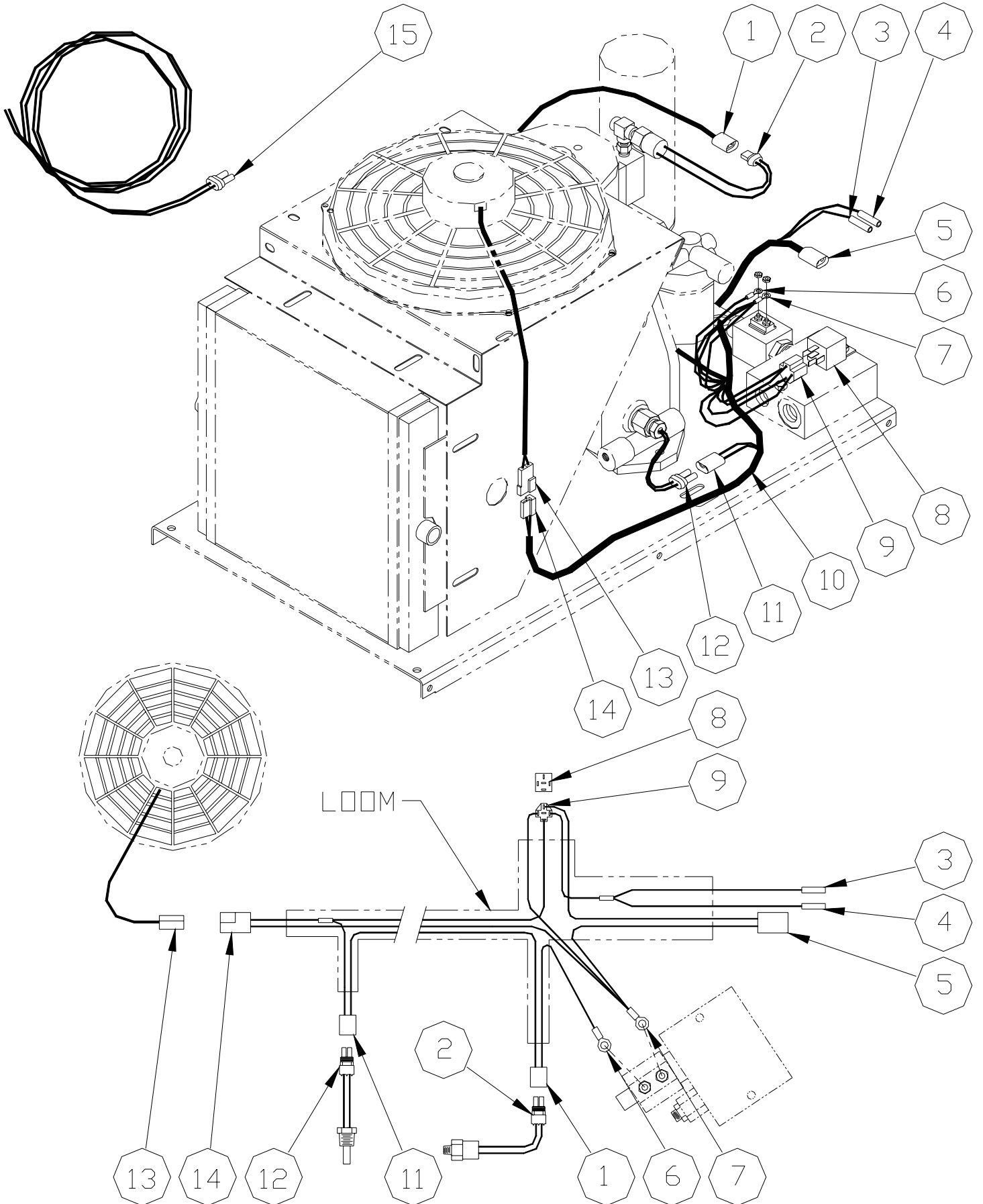

ELECTRICAL HARNESS AND ROUTING

1.)	MAIN HARNESS CONNECTION TO NORMALLY CLOSED BLOW DOWN PRESSURE SWITCH. LIGHT BLUE AND BLACK. SWITCH OPENS FOR APPROXIMATELY 40 SECONDS AFTER SHUTDOWN AND CLOSE WHEN COMPRESSED AIR IS RECEIVED FROM SYSTEM.
2.)	301421 - BLOW DOWN PRESSURE SWITCH CONNECTION TO MAIN HARNESS. LIGHT BLUE AND BLACK.
3.)	12V POWER RELAY COIL SUPPLY FOR HYDRAULIC SOLENOID ACTIVATION. FROM COMPRESSOR ON/OFF SWITCH GREEN
4.)	12V POWER FEED TO ENGINE SPEED CONTROL. DARK BLUE
5.)	MAIN POWER AND GROUND TO COMPRESSOR UNIT CONNECTION LOCATION OUTSIDE OF CANOPY ALONG WITH BOTH RELAY ACTIVATION WIRES.
6.)	POWER TO SOLENOID (LIGHT BLUE) MAIN HARNESS.
7.)	SYSTEM GROUND – BLACK X 3 MAIN HARNESS.
8.)	300211 – RELAY, WIRED NORMALLY OPEN AND CLOSES WITH 12V SIGNAL FROM 3 OR 4 TO START COMPRESSOR PACKAGE.
9.)	RELAY CONNECTION – MAIN HARNESS VIEWED FROM WIRE SIDE OF PLUG. DARK BLUE RIGHT SIDE, BLACK LEFT SIDE, RED TOP AND BOTTOM. NO WIRE IN CENTER.
10.)	301391 - HARNESS, MAIN WIRING.
11.)	MAIN HARNESS CONNECTION TO NORMALLY CLOSED HI COMPRESSOR OIL TEMP SHUT DOWN SWITCH. RED POWER – BLACK POWER.
12.)	300320-001 - HIGH OIL TEMP SHUT DOWN SWITCH – BLACK X 2
13.)	CONNECTION TO MAIN HARNESS TO OIL COOLING FAN. RED POWER – BLACK GROUND.
14.)	MAIN HARNESS CONNECTION AT FAN. RED POWER – BLACK GROUND.
15.)	301392 - HARNESS MAIN POWER AND GROUND CONNECTION FROM TRUCK TO CONNECTION #5 OF HARNESS OF COMPRESSOR PACKAGE.

HYDRAULIC SYSTEM

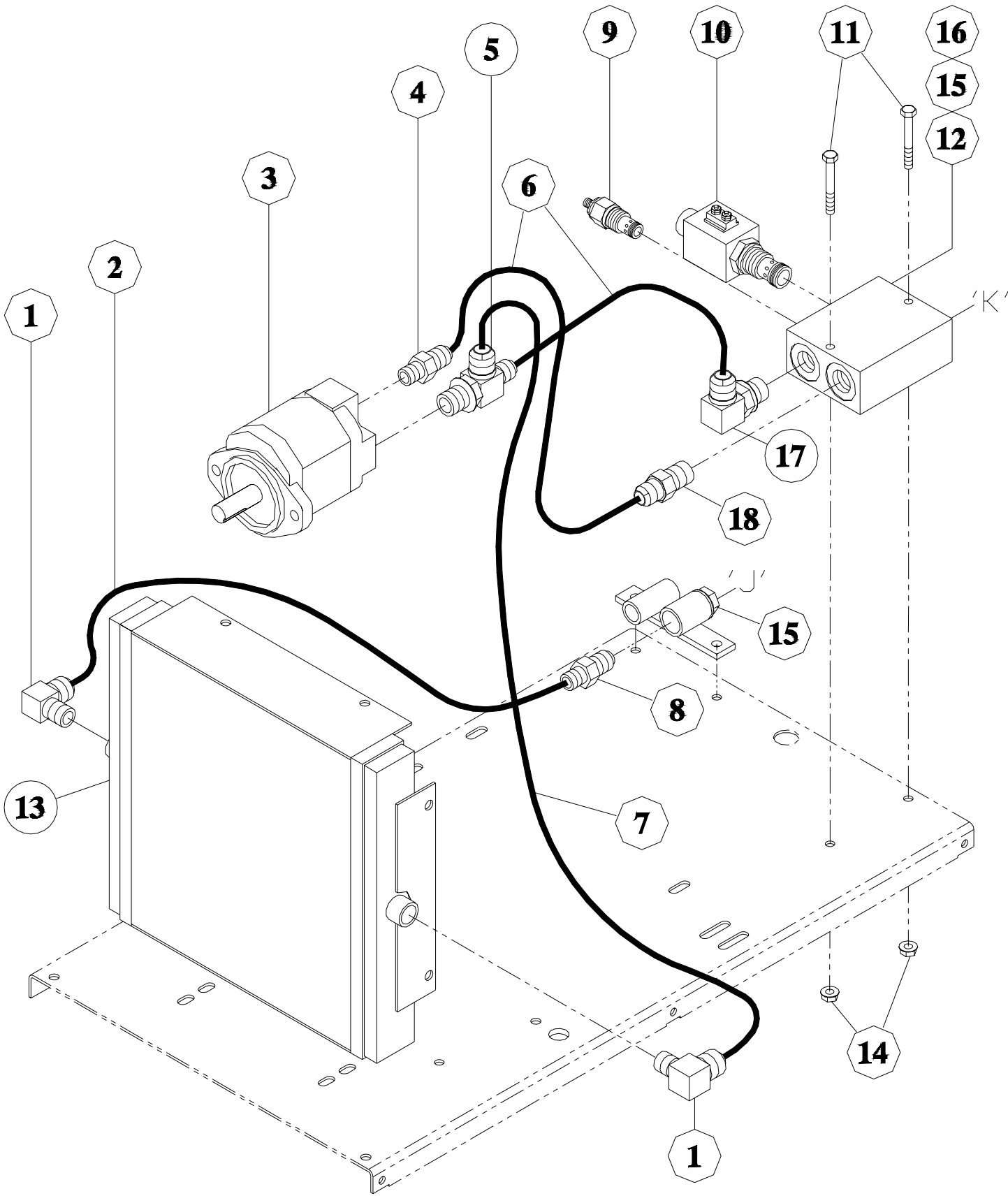

HYDRAULIC SYSTEM

ITEM	PART NUMBER	DESCRIPTION	QTY.
1	960212-050	ELBOW, 1/2" NPT X 3/4" JIC	2
2	975512-036	3/4" HOSE X 36" LG	1
3	301256	MOTOR, HYDRAULIC .87	1
4	970512-088	CONNECTOR, 3/4" JIC X 10 SAE	1
5	976512-106	TEE, 3/4"M SAE X 3/4"M JIC	1
6	975512-027	3/4" HOSE X 27" LG	2
7	975412-033	3/4" HOSE X 33" LG	1
8	960112-075	CONNECTOR, 3/4" NPT X 3/4" JIC	1
9	301251	VALVE, HYD.RELIEF	1
10	301250	SOLENOID, HYD. N.O.	1
11	929105-250	BOLT, HEX 5/16"-18 X 2-1/2" GR5	2
12	301249	BLOCK, HYDRAULIC	1
13	300836	COOLER, OIL 12 X 13.5	1
14	924305-166	NUT, NYLOC 5/16-18 GR5	2
15	301663	PLUG, PLASTIC PIPE 3/4" NPT	2
16	902915-030	PLUG, PIPE 3/4" NPT RECESSED	1
17	960212-075	ELBOW, 3/4" NPT X 3/4" JIC	1
18	970512-106	CONNECTOR, 3/4" NPT X 12 SAE	1

‘J’ LOW PRESSURE HYDRAULIC OUTLET BACK TO TANK 3/4” NPT

‘K’ HIGH PRESSURE HYDRAULIC INLET FROM PUMP - 1 1/16 SAE

COMPRESSOR AND MOUNTING

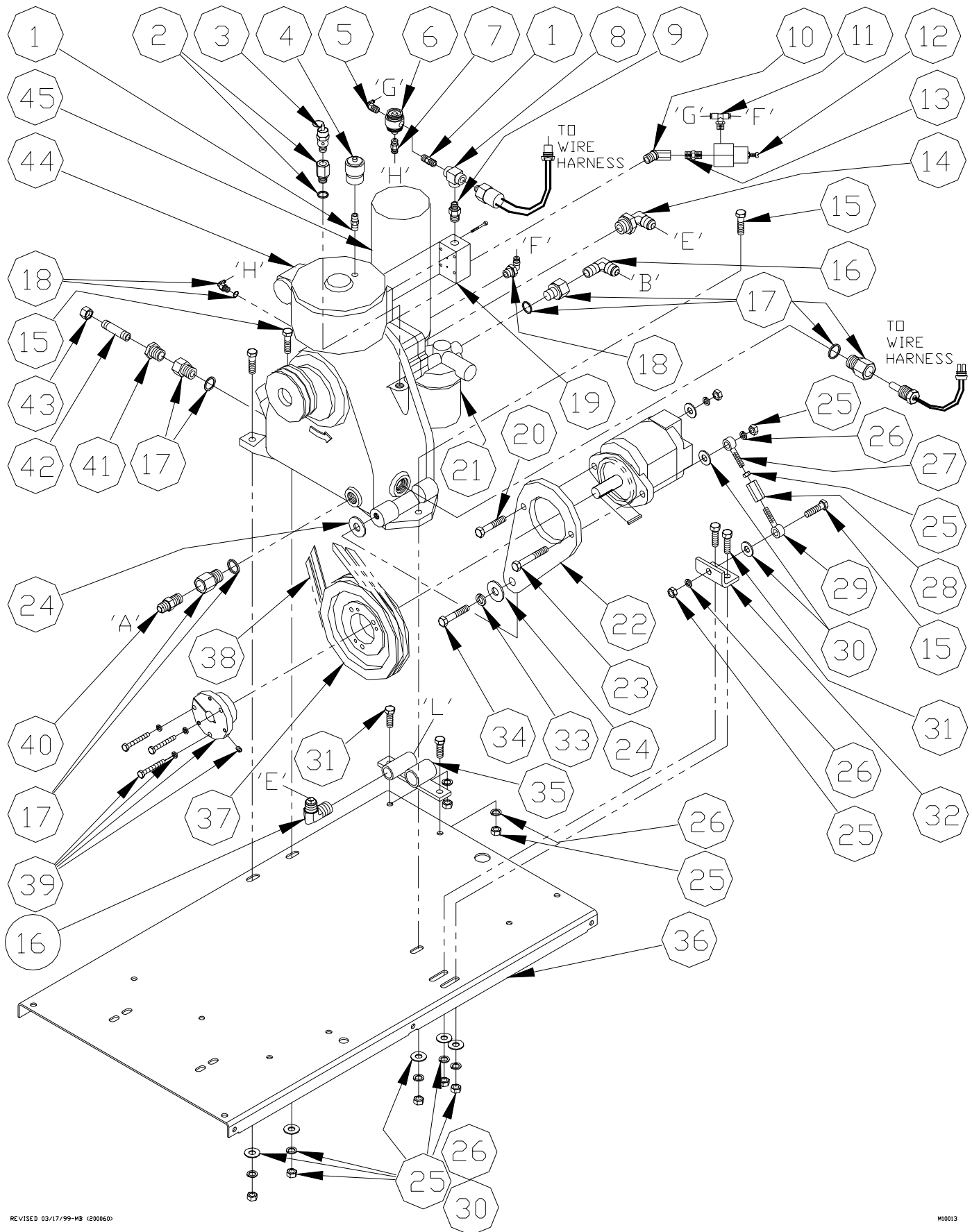

COMPRESSOR AND MOUNTING

ITEM	PART NUMBER	DESCRIPTION	QTY.
1	922202-000	NIPPLE, PIPE 1/8" X CLOSE SCH. 80	1
2	970804-025	ADAPTER & SEAL 1/4" NPT X 1.4" BSPP	1
3	300330-200	VALVE, RELIEF 1.4" NPT X 200#	1
4	300853	INDICATOR, AIR FILTER	1
5	971325-025	ELBOW, TUBE 5/32" TUBE X 1/4" NPT	1
6	301827	VALVE, BLOW DOWN 1/8" N.C.	1
7	971225-025	CONNECTOR, TUBE 5/32" TUBE X 1/4" NPT	1
8	960602-012	TEE, PIPE 1/8" FEMALE	1
9	961604-012	NIPPLE, HEX RED 1/4" X 1/8"	2
10	960804-025	ELBOW, 1/4" NPT X 1/4" FPT X 45°	1
11	971425-025	TEE, 5/32" TUBE X 5/32 TUBE X 1/4 NPT	1
12	300057	VALVE, REG 1.4"	1
13	960404-025	NIPPLE, HEX 1/4" X 1/4"	1
14	970608-050	ELBOW, 1/2" BSPP X 1/2" JIC	1
15	929806-150	BOLT, HEX 3/8-16 UNC X 1 1/4"	4
16	960208-050	ELBOW, 1/2" NPT X 1/2" JIC	1
17	970808-050	ADPTER, 1/2" BSPP X 1/2" NPT	4
18	971004-012	ELBOW, TUBE 5.32" TUBE X 1/8" BSPP	2
19	301372-1	MANIFOLD, AIR REG/BLOW DOWN	1
20	929806-200	BOLT, HEX 3/8-16 UNC X 2"	1
21	300324	ELEMENT, OIL FILTER	1
22	301262	PLATE, HYD MOTOR MTG.	1
23	929806-250	BOLT, HEX 3/8"-16 UNC X 2 1/2"	1
24	928208-112	WASHER, FLAT 1/2"	2
25	926006-337	NUT, HEX 3/8"	11
26	937806-094	WASHER, LOCK 3/8"	10
27	301259	EYEBOLT, 3/8"-16 RH	1
28	301258	NUT, TURNBUCKLE 3/8"-16	1
29	301257	EYEBOLT, 3/8"-16 LH	1
30	938206-071	WASHER, FLAT 3/8"	10
31	929806-100	BOLT, HEX 3/8"-16 UNC X 1"	4
32	301370	BRACKET, BELT ADJUSTER	1
33	937808-125	WASHER, LOCK 1/2"	1
34	929808-150	BOLT, HEX GR8 1/2"-20 UNF X 2 1/4"	1
35	301260	BRACKET, AIR SERVICE VALVE	1
36	301334	BASE, THR 35/175	1
37	300807-005	PULLEY, 3V-2-GROOVE	1
38	300742-335	BELT, 3VX335	2
39	300745-075	BUSING, SDS 3/4" X 3/16" KEY	1
40	960108-050	CONNECTOR, 1/2" NPT X 1/2" JIC	1

COMPRESSOR AND MOUNTING

ITEM	PART NUMBER	DESCRIPTION	QTY.
41	907602-010	BUSHING, RED 1/2" X 1/4"	1
42	922104-020	NIPPLE, PIPE 1/4" X 2"	1
43	906030-010	CAP, PIPE HEX 1/4"	1
44	301255	COMPRESSOR, 35/175 RS	1
45	301416	ELEMENT, COALESCER NK40	1

'A' SUMP OIL OUT TO THERMAL VALVE (HOSE ASSY. 975508-014)

'B' MIXED OIL FROM THERMAL VALVE TO COMPRESSOR
(HOSE ASSY. 975408-021)

'E' COMPRESSED AIR OUT TO CUSTOMER CONNECTION (HOSE ASSY. 975408-017)

'F' BLOW DOWN AIR TO REGULATOR TEE

'G' BLOW DOWN AIR FROM REGULATOR TEE TO BLOW DOWN VALVE

'H' BLOW DOWN VALVE AIR SIGNAL TO BLOW DOWN VALVE

'L' 1/2" FPT CUSTOMER AIR OUT CONNECTION

DECAL & IDENTIFICATION SYSTEM

ITEM	PART NUMBER	DESCRIPTION	QTY.
1	300038	DECAL, DANGER HOT OIL	1
2	3001483	DECAL, SERIES 35	2
3	300204	PLATE, SERIAL BOSS	1
4	300040	DECAL, DANGER BREATHING AIR	1
5	300039	DECAL, WARNING READ MANUAL	1
6	300649	DECAL, DIAMOND AIR	2
7	302694	DECAL, COMPRESSOR FLUID FILL	1
8	300913	DECAL, OIL DRAIN	1

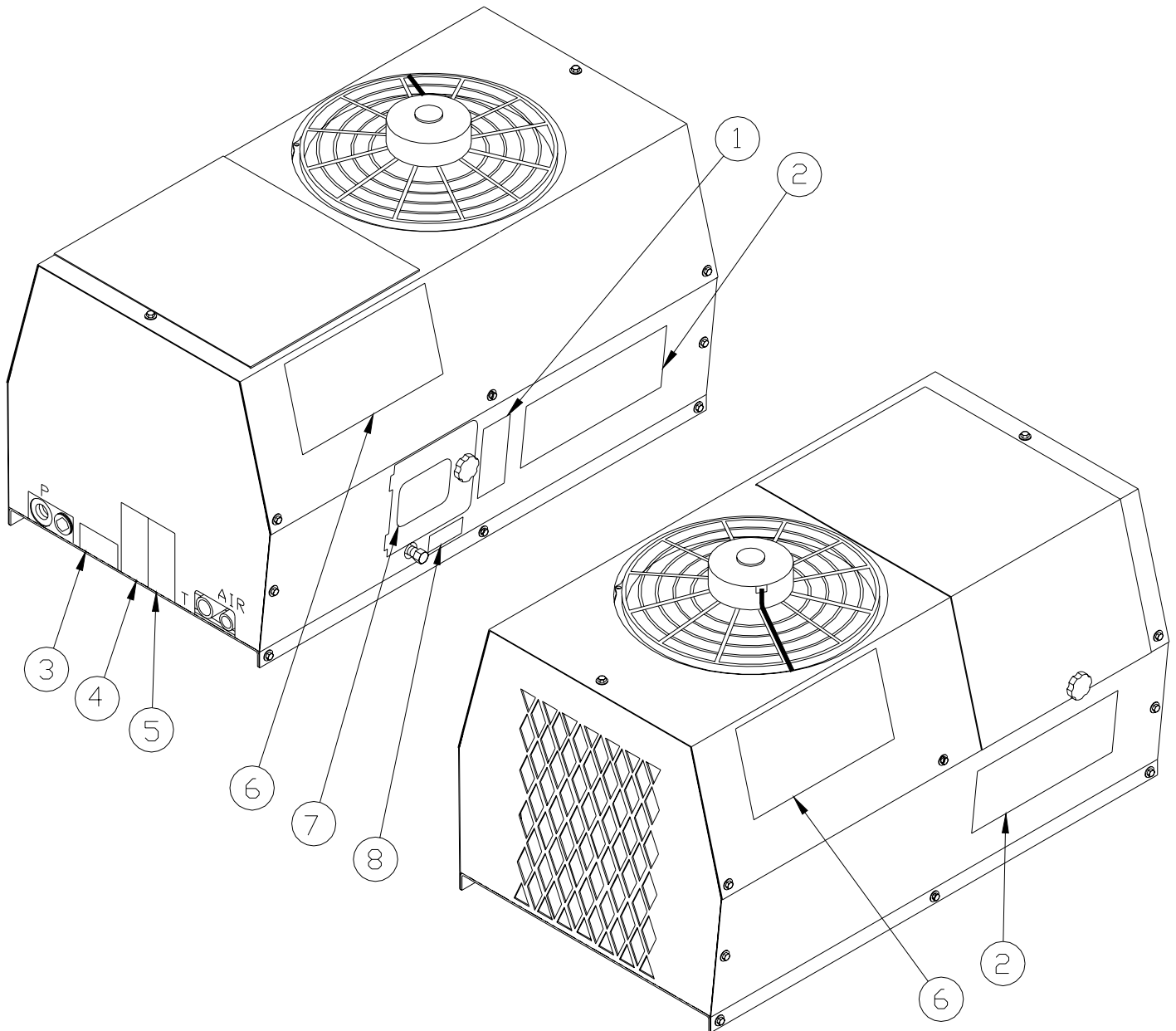

RECOMMENDED SPARE PARTS LIST

PART NUMBER	DESCRIPTION	QTY.
300324	OIL FILTER ELEMENT	1
301413	AIR FILTER ELEMENT	1
301416	SPIN-ON COLAESCER	1
300187	REGULATOR REPAIR KIT	1
301414	COMPRESSOR SHAFT SEAL REPAIR KIT	1
301428	HYDRAULIC MOTOR SHAFT SEAL KIT	1
300742-335	DRIVE BELTS	2
300320-001	HI-TEMPERATURE SHUTDOWN SWITCH	1

SERVICE QUESTIONNAIRE

DATE: _____

1. Information given by: _____
2. Information received by: _____
3. Has anyone helped you: Yes _____ No _____
4. Distributor: _____
5. End-User: _____
6. Phone Number: _____
7. Make and Model for PTO: _____
8. BOSS Serial #: _____
9. Make and Model of Engine: _____
10. Engine: _____
11. Transmission: _____

12. Nature of Problem: _____

13. Engine RPM: _____
14. Compressor RPM: _____
15. Action Taken: _____

ADDITIONAL COMMENTS: _____

WARRANTY

SECTION

BOSS Industries, Inc. warrants that this Rotary Screw Compressor unit conforms to applicable drawings and specifications approved in writing by BOSS. The unit assembly will be free from defects in material and workmanship for a period of two (2) years from the date of initial operation or thirty (30) months from the date of shipment, whichever period first expires. All other components and parts of BOSS manufacture, will be free from defects in material and workmanship for a period of one (1) year from the date of initial operation or eighteen (18) months from the date of shipment, whichever period first expires. If within such period BOSS receives from the Buyer written notice of and alleged defect in or nonconformance of the unit, all other components and parts of BOSS manufacture and if in the judgment of BOSS these items do not conform or are found to be defective in material of workmanship, BOSS will at its option either, (a) furnish a Service Representative to correct defective workmanship, or (b) upon return of the item F.O.B. BOSS original shipping point, repair or replace the item or issue credit for the replacement item ordered by Buyer, (Defective material must be returned within thirty (30) days of return shipping instructions from BOSS. Failure to do so within specified time will result in forfeiture of claim), or (c) refund the full purchase price for the item without interest. Factory installed units will also include warranty on installation for a period of one (1) year. This warranty does not cover damage caused by accident, misuse or negligence. If the compressor unit is disassembled the warranty is void. BOSS's sole responsibility and Buyer's exclusive remedy hereunder is limited to such repair, replacement, or repayment of the purchase price. Parts not of BOSS manufacture are warranted only to the extent that they are warranted by the original manufacture. BOSS shall have no responsibility for any cost or expense incurred by Buyer from inability of BOSS to repair under said warranty when such inability is beyond the control of BOSS or caused solely by Buyer.

There are no other warranties, express, statutory or implied, including those of merchantability and of fitness of purpose; nor any affirmation of fact or representation which extends beyond the description of the face hereof.

This warranty shall be void and BOSS shall have no responsibility to repair, replace, or repay the purchase price of defective or damaged parts or components resulting directly or indirectly from the use of repair or replacement parts not of BOSS manufacture or approved by BOSS or from Buyer's failure to store, install, maintain, and operate the compressor according to the recommendations contained in the Operating and Parts Manual and good engineering practice. The total responsibility of BOSS for claims, losses, liabilities or damages, whether in contract or tort, arising out of or related to its products shall not exceed the purchase price. In no event shall BOSS be liable for any special, indirect, incidental or consequential damages of any charter, including, but not limited to, loss of use of productive facilities or equipment, loss of profits, property damage, expenses incurred in reliance on the performance of BOSS, or lost production, whether suffered by Buyer or any third party.

BOSS Industries, Inc.

720 Boyd Boulevard

LaPorte, IN 46352

As claims, policies and procedure are governed by the terms of the BOSS Industries, Inc. warranty, it is necessary to outline some of the more important provisions.

The BOSS warranty applies only to new and unused products which, after shipment from the factory, have not been altered, changed, repaired or mistreated in any manner whatsoever. Normal maintenance items such as lubricants and filters are not warrantable items.

Parts not of BOSS manufacture are warranted only to the extent they are warranted by the original manufacturer.

Damage resulting from abuse, neglect, misapplication or overloading of a machine, accessory or part is not covered under warranty.

Deterioration or wear occasioned by chemical and/or abrasive action or excessive heat shall not constitute defects.

Parts replacement and/or correction of defective workmanship will normally be handled by BOSS or their authorized distributor.

Failure to file a detailed warranty claim/service report for each occurrence of material defect of defective workmanship will cause warranty claim to be rejected.

Defective material must be returned within 30 days of receipt of shipping instructions. Failure to do so within specified time will result in forfeiture of claim.

The distributor is responsible for the initial investigation and write up of the warranty claim.

Distributor shall be allowed no more than 30 days from date of repair to file a warranty claim/service report.

Warranty for failure of BOSS replacement parts covers the net cost of the party only, not labor and mileage.

The BOSS warranty does not cover diagnostic calls and travel. That is time spent traveling to the machine to analyze the problem and returning with the proper tools and parts to correct the problem.

BOSS will deduct from allowable credits for excess freight caused by sender failing to follow return shipping instructions.

Distributors or end-users automatically deducting the value of a warranty claim from outstanding balances due and payable to BOSS prior to receiving written notification of BOSS approval of the warranty claim may be subject to forfeiture of the entire claim.

The warranty policy and procedures outlined here within are detailed to provide the claimant with the information necessary when filing a warranty claim, and enabling BOSS the ability to best serve it's customers.

WARRANTY CLAIMS - GENERAL

An approved claim depends on the following provision:

1. A warranty claim/service report # must be issued by BOSS. (See filing procedures).
2. Failed part must be returned within 30 days, freight prepaid, with receipt of warranty claim/service report.
3. Part is definitely defective.
4. Workmanship is definitely defective.
5. Machine is within warranty period.
6. Machine has been operating within design conditions.

Claims made by distributors must be verified by distributor prior to contracting BOSS.

WARRANTY CLAIMS - FILING PROCEDURES

1. Initiate through purchase order for warranty part or request for credit.
2. Warranty Claims/Service Report will accompany replacement part. When returning failed part to the factory for warranty credit, fill out all information requested on Warranty Claims/Service Report when it is returned to you with replacement part.
3. BOSS will confirm disposition of failed part within 30 days, and or request additional information.
4. Claim acceptance or denial will result in release of a credit or confirmation letter of denial.
5. BOSS will consider each claim on it's own merit and reserves the right to accept or reject claim request. In case of air-ends, these will be returned to the manufacturer for their analysis/input.
6. Send Warranty Claim/Service Report request to:

BOSS Industries, Inc.

720 Boyd Boulevard

LaPorte, IN 46350

Parts returned to the factory must be properly packaged to prevent damage during shipment. Damage to a part as a result of improper handling or packing could be cause for claims disallowance of credit. When addressing the package for shipment, the following information must be on the outside of or tagged clearly to package.

1. Return Goods Authorization.
2. Distributor or end-users return address.
3. Correct factory address.
4. Warranty Claim/Service Report #.
5. Number of packages pertaining to each claim.

NOTE: Our warranty requires that all defective parts be returned to BOSS freight prepaid. Items sent without RGA number will not be accepted.

DAMAGE IN TRANSIT

Do not return damaged merchandise to BOSS Industries, Inc. please follow claim procedure.

1. Loss in transit:

The merchandise in our kit or provided in our factory installations has been thoroughly inspected or carefully installed and tested before leaving our plant. However, regardless of the care taken at the factory, there is a possibility that damage may occur in shipment. For this reason, it is recommended that the unit be carefully inspected for evidence of possible damage or malfunction during the first few hours of operation. Responsibility for the safe delivery of the kit or factory installed unit was assumed by the carrier at the time of shipment. Therefore, claims for loss or damage to the contents of the kit or factory installed unit should be made upon the carrier.

2. Concealed loss or damage:

Concealed loss or damage means loss or damage which does not become apparent until the kit is unpacked or the factory installed unit is run by the end-user. The contents of the kit or factory installed unit may be damaged due to rough handling while in route to its destination, even though the kit or factory installed unit shows no external damage. When the damage is discovered upon unpacking, make a written request for inspection by the carrier agent within fifteen days of delivery date. Then file a claim with the carrier since such damage is the carrier's responsibility.

SCREW COMPRESSOR AIR-END EXCHANGE PROGRAM

Replacement air-ends are available from the factory. For current prices and availability, contact BOSS or an authorized BOSS distributor. Prices are F.O.B. shipping point. Prices do not include labor for removal or installation.

NOTES