

**BOSS MODEL BGSD POWERMAX  
6.2 KW GENERATOR  
OPERATORS, MAINTENANCE  
AND PARTS MANUAL**

**OPERATORS, MAINTENANCE, AND PARTS MANUAL  
BOSS MODEL BGS D POWERMAX 6.2 GENERATOR**

**TABLE OF CONTENTS**

Operation & Maintenance Section

General Instruction/Danger Warning ..... 2

Equipment Description ..... 3-4

Safety Rules ..... 5-7

Operating The Generator ..... 8

Generator Maintenance ..... 9

Parts and Illustration Section ..... 10-22

Warranty Section

Warranty Information ..... 23-27

## GENERAL INFORMATION/SPECIFICATIONS

Every effort has been expended to make sure that the information in this manual is both accurate and current. However, BOSS reserves the right to change, alter or otherwise improve the product at any time without prior notice.

Bold printed **DANGER** boxes point out important safety instructions, which if not followed, could endanger personal safety and/or property.

Read all safety and operations manuals for both the PTO Air Compressor and the Generator prior to operating this unit. Follow all instructions in both manuals.

### DANGER

**THIS GENERATOR IS DESIGNED FOR OUTDOOR USE ONLY. DO NOT USE THIS GENERATOR INSIDE ANY BUILDING OR ENCLOSURE. DEADLY CARBON MONOXIDE GAS MAY CAUSE FATAL INJURIES. IN ADDITION, A FIRE OR AN EXPLOSION MAY OCCUR. NO USER-PERFORMED MODIFICATIONS, INCLUDING VENTING OF EXHAUST AND/OR COOLING VENTILATION, WILL ELIMINATE THE DANGER.**

### DANGER

**IF THIS UNIT IS USED FOR BACK-UP POWER IN THE EVENT OF A UTILITY POWER FAILURE, THE FOLLOWING STEP MUST BE TAKEN: BEFORE CONNECTING THE GENERATOR TO AN ELECTRICAL SYSTEM, OPEN THE MAIN CIRCUIT BREAKER OR MAIN SWITCH SERVING THE SYSTEM, TO ISOLATE THE GENERATOR SYSTEM FROM THE ELECTRIC UTILITY. FAILURE TO ISOLATE THE GENERATOR AND UTILITY SYSTEMS MAY RESULT IN DAMAGE TO THE GENERATOR AND MAY ALSO RESULT IN INJURY OR DEATH TO ELECTRIC UTILITY WORKERS, DUE TO A BACK FEED OF ELECTRICAL ENERGY.**

## EQUIPMENT DESCRIPTION

This generator is truck chassis mounted, revolving field, alternating current (AC) generator. The generator is driven off a power takoff (PTO) drive shaft system. It is designed to supply electrical power for operating compatible electrical lighting, appliance tool and motor loads. This manual contains information for a generator that operates 120 and/or 240 volts, single phase, 60 Hz devices that require up to the rated watts of your specific generator. Refer to the identification tag for specific rating.

***CAUTION: Do not exceed the generators wattage/ampere capacity. Add up the rated watts of all devices you are connecting to the generator receptacles at one time. This total should not be greater than the rated output watts for this generator. In most cases rated watts of the electrical device can be found on the device nameplate. If the device nameplate gives only volts and amps, multiply volts times amps to obtain watts (volts X amps = watts).***

The generator's revolving field is driven at 1800 rpm by the compressor engine. The generator drive consists of the following:

1. A drive shaft and pulley that powers the generator through a belt arrangement.

## **EQUIPMENT DESCRIPTION**

### **DANGER**

**OPERATORS MUST NOT TAMPER WITH ENGINE GOVERNED SPEED. HIGH OPERATING SPEEDS ARE DANGEROUS AND INCREASE RISK OF PERSONAL INJURY OR DAMAGE TO EQUIPMENT. THE GENERATOR SUPPLIES CORRECT RATED FREQUENCY AND VOLTAGE ONLY WHEN RUNNING AT PROPER GOVERNED SPEED. INCORRECT FREQUENCY AND/OR VOLTAGE CAN DAMAGE SOME CONNECTED ELECTRICAL LOADS. ONLY TRAINED SERVICE TECHNICIANS SHOULD WORK ON THE CONTROLLER UNIT.**

### **DANGER**

**ELECTRICAL SURGES AND SPIKES CAN CAUSE SERIOUS DAMAGE TO YOUR SYSTEM AND EVERYTHING PLUGGED IN TO IT. PROPER SURGE PROTECTORS SHOULD BE USED BETWEEN THE RECEPTACLES AND EVERY ELECTRICAL SYSTEM BEING USED. IMPROPERLY TUNED ENGINES CAN FORCE THE ELECTRONIC ENGINE SPEED CONTROL TO SPIKE AND FADE THUS CREATING DAMAGING ELECTRICAL SURGES.**

### **DANGER**

**NEVER WELD TO TRUCK CHASSIS, AS THIS WILL CAUSE DAMAGE TO MANY ELECTRICAL OR ELECTRONIC COMPONENTS GROUNDED TO VEHICLES CHASSIS.**

## SAFETY RULES

**CAUTION:** *These safety rules are generator specific and are to be used in conjunction with the PTO air compressor manual and safety rules. All safety and operation procedures of the air compressor must be followed when using the generator. These rules are not all inclusive. Please refer to departmental and company safety procedure for additional guidelines.*

### DANGER

**THIS GENERATOR IS DESIGNED FOR OUTDOOR USE ONLY. DO NOT USE THIS GENERATOR INSIDE ANY BUILDING OR ENCLOSURE. DEADLY CARBON MONOXIDE GAS MAY CAUSE FATAL INJURIES. IN ADDITION A FIRE OR AN EXPLOSION MAY OCCUR. NO USER-PERFORMED MODIFICATIONS, INCLUDING VENTING OF EXHAUST AND/OR COOLING VENTILATION WILL ELIMINATE THE DANGER.**

### DANGER

**IF THIS UNIT IS USED FOR BACK-UP POWER IN THE EVENT OF A UTILITY POWER FAILURE, THE FOLLOWING STEP MUST BE TAKEN: BEFORE CONNECTING THE GENERATOR TO AN ELECTRICAL SYSTEM, OPEN THE MAIN CIRCUIT BREAKER OR MAIN SWITCH SERVING THE SYSTEM, TO ISOLATE THE GENERATOR SYSTEM FROM THE ELECTRIC UTILITY. FAILURE TO ISOLATE THE GENERATOR AND UTILITY SYSTEMS MAY RESULT IN DAMAGE TO THE GENERATOR AND MAY ALSO RESULT IN INJURY OR DEATH TO ELECTRIC UTILITY WORKERS, DUE TO A BACK FEED OF ELECTRICAL ENERGY.**

This generator set was designed and manufactured for specific applications. Do not attempt to modify the unit or use it for any application it was not designed for.

If you have any questions about your generator's application, ask your Dealer/Distributor or consult the factory.

## SAFETY RULES

The manufacturer could not possibly anticipate every circumstance that might involve a hazard. For that reason warnings in the manual and warnings on tags or decals affixed to the unit are not all inclusive. If you intend to handle, operate or service the unit by a procedure or method not specifically recommended by the manufacturer, first make sure that such a procedure or method will not render this equipment unsafe or pose a threat to you and others.

- Read this manual carefully and become familiar with your generator set. Know its applications, its limitations and any hazard involved.
- The generator produces a very powerful voltage that can cause an extremely dangerous shock. Avoid contact with bare wires, terminals, etc... Never permit any unqualified person to operate or service the generator.
- Never handle any kind of electrical cord or device while standing in water, while barefoot or while hands or feet are wet. Dangerous electrical shock will result.
- Use a ground fault circuit interrupter in any damp or highly conductive area (such as metal decking or steel work).
- Do not use any worn, bare, frayed or otherwise damaged electrical cord sets with the generator. Using any defective cord set may result in electrical shock or damage to equipment and/or property.
- Operate generator where it will not be exposed to excessive dirt, dust or corrosive vapors.
- Gasoline and natural gas are highly FLAMMABLE and their vapors are EXPLOSIVE. Do not permit smoking, open flames, sparks or heat in the vicinity while exposed to these gases.
- The trucks exhaust emits DEADLY carbon monoxide gas. This dangerous gas, if breathed in sufficient concentrations, can cause unconsciousness or even death. Operate this equipment only in the open air where adequate ventilation is available.
- The PTO generator requires an adequate flow of cooling air for its continued proper operation. Never operate the unit inside any room or enclosure where the free flow of cooling air into and out of the unit might be obstructed. Without sufficient cooling air flow, the generator quickly overheats, damaging the generator or nearby property. Never operate the generator where ambient temperatures exceed 100°F.

## **SAFETY RULES**

- Never, engage/disengage, the engine-generator with electrical loads connected to receptacles with the connected devices turned ON. Start the engine and let it stabilize before connecting electrical loads. Disconnect all electrical loads before disengaging the generator.
- Do not insert any object through cooling slots of the generator. You could damage the unit or injure yourself.
- Never operate generator (a) in any enclosed building, (b) if engine speed changes, (c) if connected electrical devices overheat, (d) if electrical output is lost, (e) if engine or generator sparks, (f) if flame or smoke is observed while unit is running, (g) if unit vibrates excessively.

## **GROUNDING THE GENERATOR**

The National Electric Code requires the frame and external electrically conductive parts of the generator to be properly connected to approved earth ground. Local electrical codes may also require proper grounding of the unit. Consult with a local electrician for ground requirements in your area.

Properly grounding the generator helps prevent electrical shock if a ground fault condition exists in the generator or in connected electrical devices. Proper grounding also helps dissipate static electricity, which often builds up in ungrounded devices.

## OPERATING THE GENERATOR

**CAUTION:** *Never engage or disengage the PTO-generator with electrical loads connected to the receptacles with the connected devices turned ON.*

Disconnect all electrical loads from the generator.

- Follow all safety guidelines in both the compressor and generator manuals.
- Follow all company and departmental safety procedures.
- Engage compressor PTO and allow for warm-up.
- Turn generator toggle switch to ON position and wait for engine RPM to increase and stabilize (about 2-5 seconds).

### **Applying Electrical Loads:**

- Plug in and turn on the desired 120 or 240 volts, single phase, 60 Hertz, AC electrical load, when finished disconnect electrical load. Turn off the generator by moving the toggle switch to the off position.

## GENERAL MAINTENANCE RECOMMENDATIONS

The general maintenance of the generator must be done in conjunction with that of the split-shaft box and the air compressor. These units are not independent in operation and maintenance of one unit will affect the other.

The Owner/Operator is responsible for making sure that all periodic maintenance tasks are completed on a timely basis; that all discrepancies are corrected; and that the unit is kept clean. Never operate a damaged or defective generator.

### GENERATOR MAINTENANCE

Generator maintenance consists of keeping the unit clean and dry. Cooling air slots in the generator must not become clogged with snow, leaves or any other foreign material.

Check the cleanliness of the generator frequently and clean when dust, dirt, oil, moisture or other foreign substances are visible on its exterior surface.

***NOTE: We DO NOT recommend using a garden hose to clean generator. If water enters generator through cooling air slots, some of the water will be retained in voids and cracks of the rotor and stator winding insulation. Water and dirt build-up on the generator internal windings will eventually decrease the insulation resistance of these windings.***

To clean the generator:

1. Use a damp cloth to wipe exterior surfaces clean.
2. Soft bristle brush may be used to loosen caked on dirt and debris.
3. A vacuum cleaner may be used to pick up loose dirt and debris.
4. Low pressure air (not to exceed 25 PSI) may be used to blow away dirt. Inspect cooling air slots and opening on the generator. These openings must be kept clean and unobstructed.

***CAUTION: Never insert any object or tool through the air cooling slots, even if the engine is not running. Damage to the unit or personal injury may result.***

***CAUTION: Never use solvents or gasoline to clean or wipe generator or external surfaces. Explosion and/or fire can result.***

***NOTE: The generator's revolving field rides on a pre-lubricated and sealed ball bearing that requires no additional lubrication for the life of the bearing.***

Check all wiring for cracked, frayed or exposed sections. Replace any bad or worn sections of wire or connectors.

**PARTS AND  
ILLUSTRATION  
SECTION**

# OPT, BGSD PWRMAX 6.2KW

60230-999

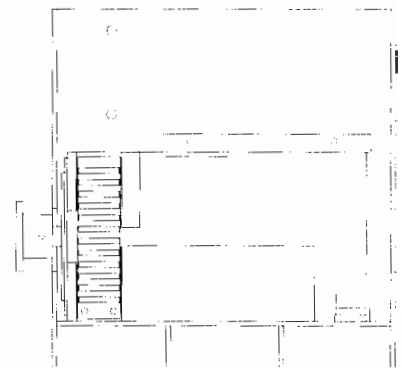
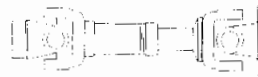
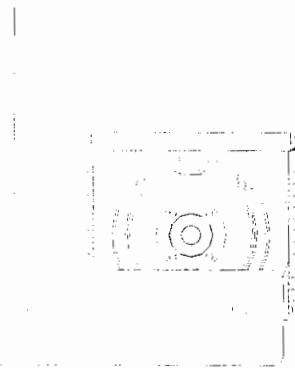
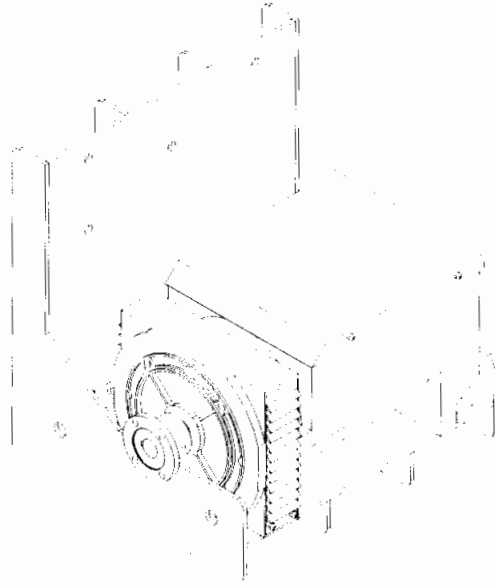

**OPT, BGSD PWRMAX 6.2KW  
60230-999**

<b>PART NUMBER</b>	<b>QTY</b>	<b>DESCRIPTION</b>
..... 302360	1.000 EACH	GEN, 6.2KW 1800RPM BG PWRMX
..... 300866	1.000 EACH	RCPTCL, 30 AMP 120V TWIST
..... 300865	1.000 EACH	COVER, RCPTCL 1GNG 120V20/30AM
..... 300864	1.000 EACH	COVER, RCPTCL DUPLEX TWO GANG
..... 300863	2.000 EACH	RCPTCL, 15 AMP 120V DUPLEX
..... 300862	1.000 BOX	BOX, RCPTCL 6 X 6 X 12
..... 300861	1.000 EACH	BREAKER, 30 AMP 120V CIRCUIT G
..... 300860	1.000 EACH	BREAKER, 20 AMP 120V CIRCUIT GF
..... 300859	1.000 EACH	BOX, CIRCUIT BREAKER 60AMP 2 S
..... 300851	1.000 EACH	GAUGE, VOLTMETER 120 AC
..... 300566-050	15.000 FOOT	CONDUIT, 1/2 PL ELEC BLUE
..... 300565-050	2.000 EACH	CONNECTOR, 1/2" CONDUIT PL GEN
..... 974212-GR	20.000 FOOT	WIRE, 12 GAUGE GREEN BOSS LOGO
..... 974212-RD	20.000 FT	WIRE, 12 GAUGE RED BOSS LOGO
..... 974212-WT	20.000 FOOT	WIRE, 12 GAUGE WHITE BOSS LOGO
..... 974212-YW	20.000 FT	WIRE, 12 GAUGE YELLOW BOSS LOG
..... 974214-BK	40.000 FOOT	WIRE, 14 GAUGE BLACK BOSS LOGO
..... 974216-BR	2.000 FOOT	WIRE, 16 GAUGE BROWN BOSS LOGO
..... 974206-BK	0.500 FOOT	WIRE, 6 GAUGE BLACK
..... 302327	1.000 EACH	BRACKET, MTG 10 KW GEN (REV 1)
..... 300156-058	1.000 EACH	YOKE, SHAFT 13/8-16 SPLINE-153
..... 300155-8021	1.000 EACH	YOKE, SLIP 1 3/8-16 SPLINE X 1
..... 300164-533	1.000 EACH	YOKE, END SR/SB

**OPT, BGSD PWRMAX 6.2KW  
60230**

<b>PART NUMBER</b>	<b>QTY</b>	<b>DESCRIPTION</b>
-1 ..... 300196-329	1.000	EACH YOKE, FLANGE 2-2-329
-1..... 300154-785	2.000	EACH U-JOINT, 5-785X
-1..... 301401	1.000	EACH FLANGE, COMPANION
-1..... 973406-050	1.000	EACH SCREW, SET 3/8 W/HOLE
-1..... 909406-125	4.000	EACH BOLT, HEX GR8 3/8-24 X 1 1/4
-1..... 925706-198	4.000	EACH NUT, NYLOC GR8 3/8-24
-1..... 926008-448	13.000	EACH NUT, HEX GR8 1/2 -13
-1..... 937808-125	13.000	EACH WASHER, LOC GR8 1/2
-1..... 929808-150	12.000	EACH BOLT, HEX GR8 1/2-13 X 1 1/2
-1..... 929808-300	1.000	EACH BOLT, HEX GR8 1/2-13 X 3

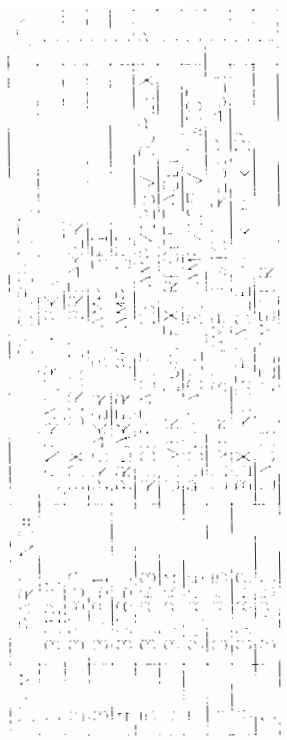

1. WIRE OFF THE GENERATOR TO BE  
 WIRE IN SERIES WITH THE GENERATOR  
 CUTOFF SWITCH AND THE OVER CHLD  
 CUTOFF RELAY TO ENGINE CTRLE  
 WIRING DIAGRAM

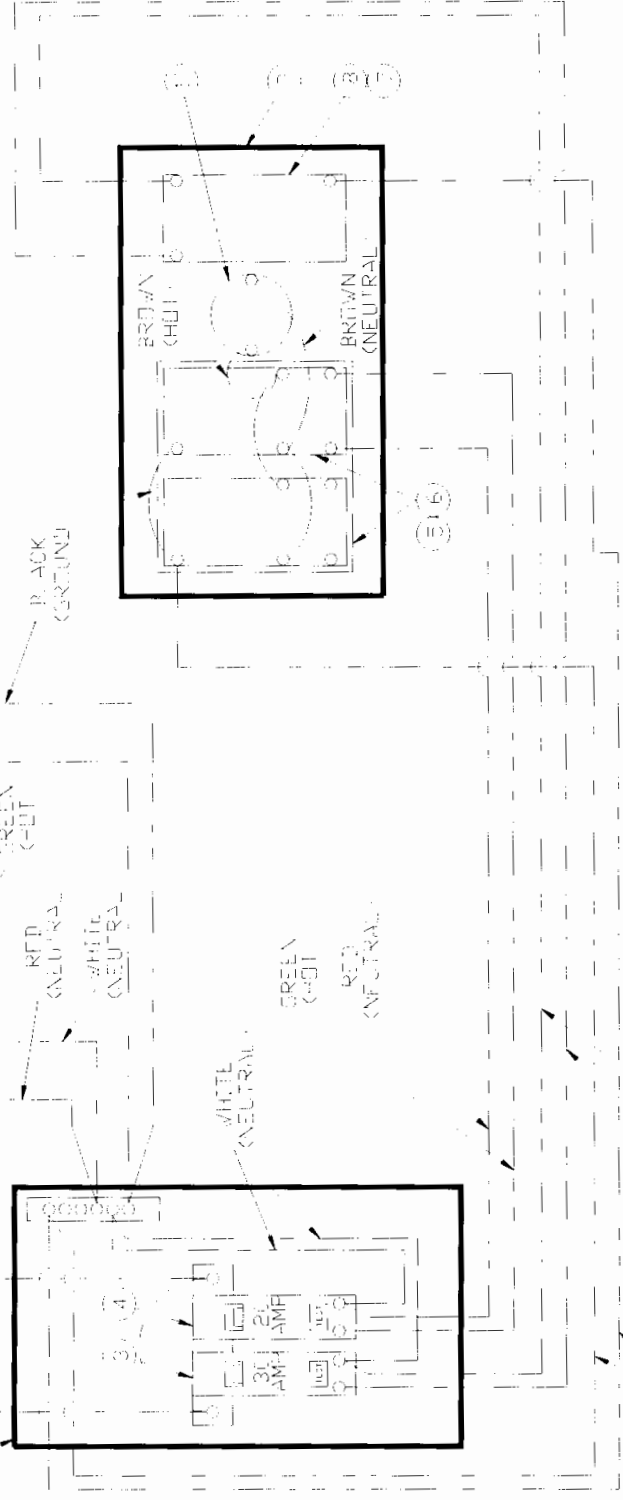
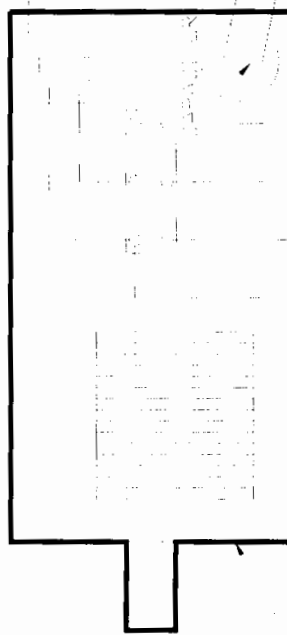

BLACK (GROUND)  
 YELLOW (CUTOFF)  
 WHITE (NEUTRAL)  
 GREEN (CUTOFF)  
 RED (NEUTRAL)

4 P/N FOR 4" X 4" GENERATOR  
 TO 311041  
 4 P/N FOR 5" X 4" GENERATOR  
 TO 311271

WCS:06

DRW: 6/27/62

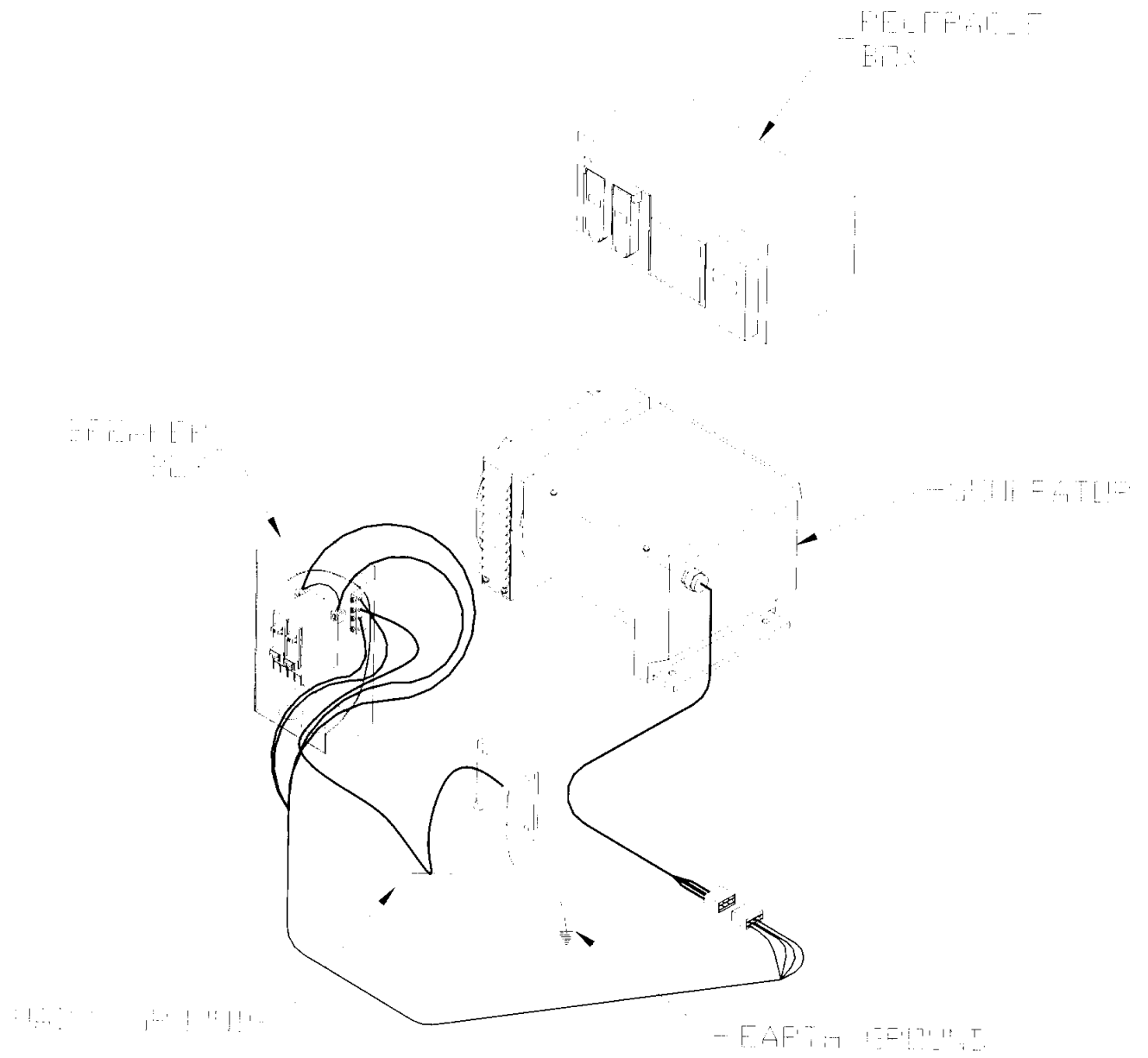

# PTO END YOKE INSTALLATION

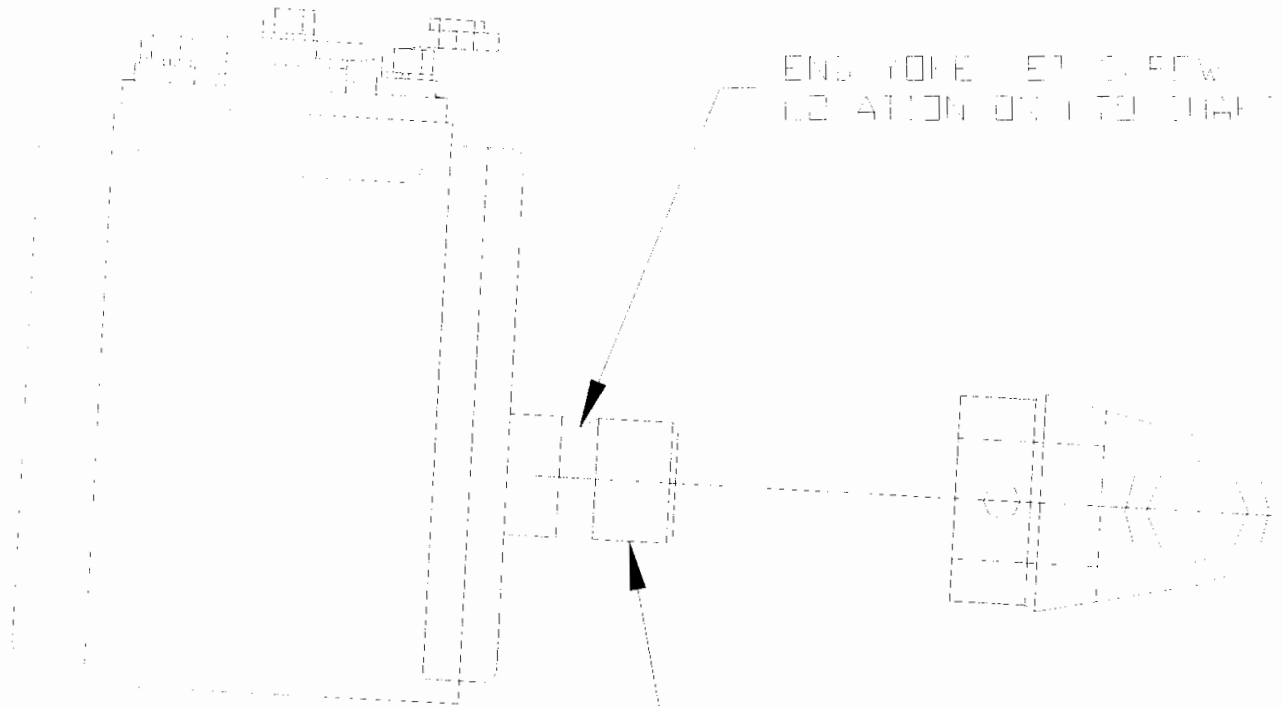

APPLY A FILM OF  
NON-CRIZING COMPOUND

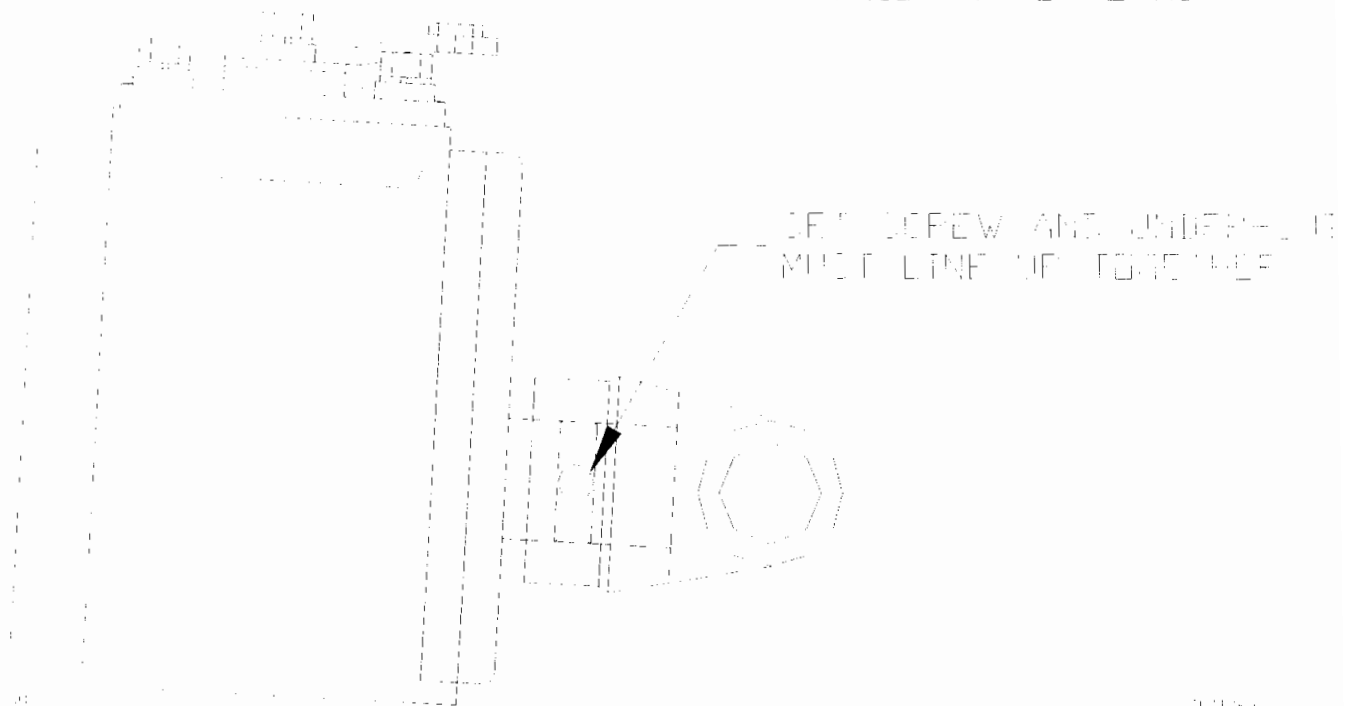

000000

# DRIVELINE RUNOUT SPECIFICATIONS

.010 T.I.R.  
.015 T.I.R.  
.010 T.I.R.  
.005 T.I.R.

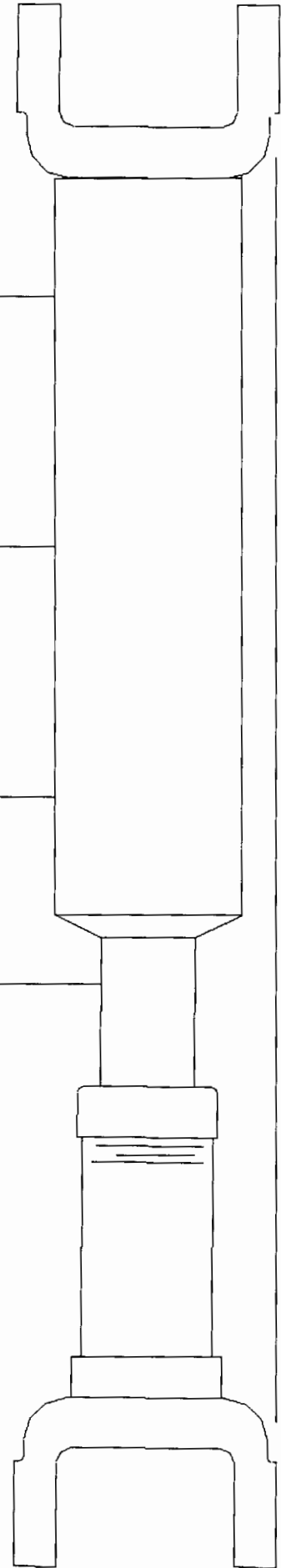

END YOKES IN PHASE

(IL1109)

11/22/99-MB

# DRIVELINE INSTALLATION TECHNIQUES

## 1. U-JOINT OPERATING ANGLES

Every U-joint that operates at an angle creates vibration.

U-joint operating angles are probably the most common cause for driveline vibration in vehicles that have been reworked or that have had auxiliary equipment installed.

When reworking a chassis or installing a new driveshaft in a vehicle, make sure that you follow the basic rules that apply to u-joint operating angles, as follows:

1. U-joint operating angles at each end of a shaft should always be at least  $1^\circ$ .
2. U-joint operating angles on each end of a driveshaft should always be equal within  $1^\circ$  of each other.
3. U-joint operating angles should not be larger than  $3^\circ$ . If more than  $3^\circ$ , make sure they do not exceed the maximum recommended angles for the RPM at which they will be operating.

A u-joint operating angle is the angle that occurs at each end of a driveshaft when the output shaft of the transmission and the input shaft of the pump are not in line. See figure.

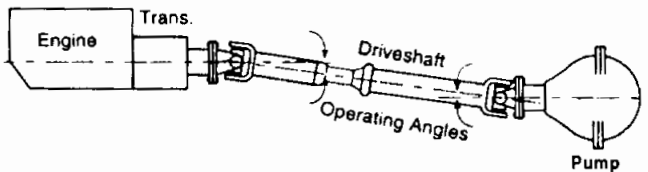

The connecting driveshaft operates with an angle at each u-joint. It is that angle that creates a vibration.

## REDUCING AND CANCELING VIBRATION

A key point to remember about u-joint operating angles: To reduce the amount of vibration, the angles on each end of a driveshaft should always be **SMALL**.

To cancel an angle vibration, the u-joint operating angles need to be **EQUAL** within  $1^\circ$  at each end of a shaft. See figure.

## 2. SINGLE PLANE AND COMPOUND U-JOINT OPERATING ANGLES

There are two types of u-joint operating angles, single plane and compound.

### SINGLE PLANE

Single plane angles occur when the transmission and pump components are in line when viewed from either the top or side, but not both.

Determine the u-joint operating angle in an application where the components are in line when viewed from the top, but not in line when viewed from the side, is as simple as measuring the slope of the components in the side view, and adding or subtracting those slopes to determine the angle. See figure.

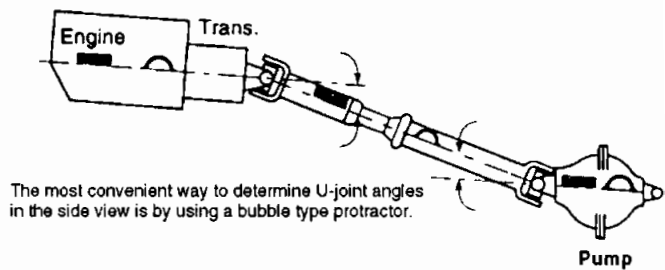

Angles in side view

These angles should be **SMALL** and equal within  $1^\circ$ .

Determine the u-joint operating angles on a shaft that is straight when viewed from the side and offset when viewed from the top requires the use of a special chart (See accompanying chart). In this type of application, the centerlines of the connected components must be parallel when viewed from the top, as shown. These angles should also be **SMALL** and equal within  $1^\circ$ . See figure.

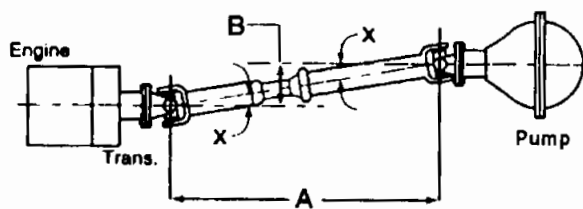

Angles in top view

Look at the angle chart and note that the smaller the offset, the smaller the resultant angle.

To reduce the possibility of vibration, keep any offset between connected points to a minimum.

# DRIVELINE INSTALLATION TECHNIQUES

There are two things which can be done to make certain single plane angles are SMALL and EQUAL:

Make sure that the transmission and pump are mounted so that their centerlines are parallel when viewed from both the side and the top.

Make sure the offset between them is small in both views.

## COMPOUND ANGLES

Compound u-joint operating angles occur when the transmission and pump are not in line when viewed from both, the top and side. Their centerlines, however, are parallel in both views. See figure.

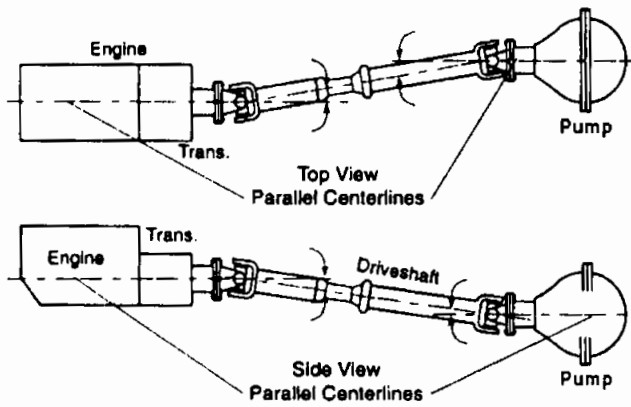

## TRUE U-JOINT OPERATING ANGLE

The true u-joint operating angle, which must be calculated for each end of the shaft with compound angles, is a combination of the u-joint operating angle in the top view, as determined from the chart, and the measured u-joint operating angle in the side view.

To determine the true u-joint operating angle for one end of a shaft, (compound angle  $C^\circ$  in the formula shown in figure below) insert the u-joint operating angle measurement obtained in the side view and the u-joint operating angle obtained from the chart into the formula.

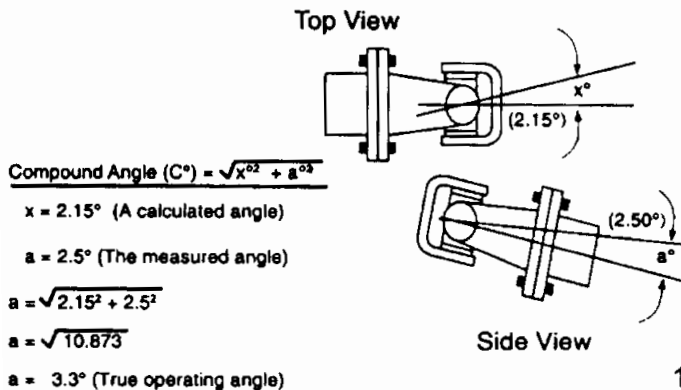

Do the same for the other end of the shaft. Compare the resultant calculated u-joint operating angle for each end. They should be EQUAL within  $1^\circ$ . If they are not, the driveshaft will vibrate.

## 3. ELIMINATING COMPOUND ANGLE INDUCED VIBRATIONS

Compound u-joint operating angles are one of the most common causes for driveline vibration. To avoid these problems, remember these important considerations:

When setting up an application that requires compound u-joint operating angles, always keep the centerlines of the transmission and pump parallel in both views.

Always keep the offset between their horizontal and vertical centerlines small.

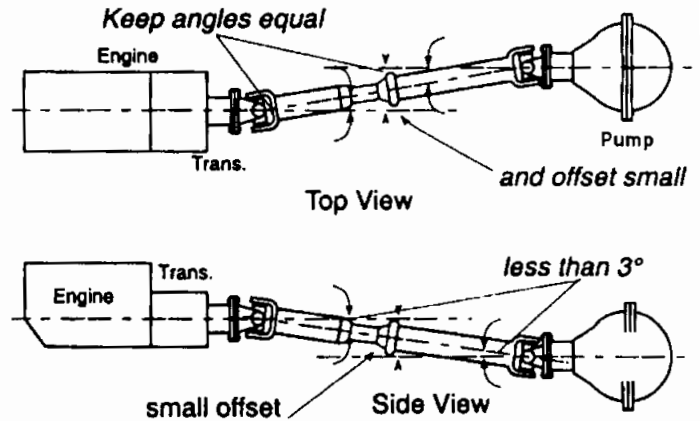

### NOTE

CENTERLINES OF TRANSMISSION AND AXLE MUST BE PARALLEL IN BOTH TOP AND SIDE VIEWS TO USE THIS METHOD OF DETERMINING TRUE U-JOINT OPERATING ANGLE. CONTACT BOSS INDUSTRIES TECHNICAL SUPPORT IF YOU HAVE AN APPLICATION WHICH CANNOT BE INSTALLED WITH THEIR CENTERLINES PARALLEL.

# DRIVELINE INSTALLATION TECHNIQUES

## 4. ANGLE SIZE

The magnitude of a vibration created by a u-joint operating angle is proportional to the size of the u-joint operating angle. BOSS INDUSTRIES recommends true u-joint operating angles of 3° or less.

Obtain the true u-joint operating angle, as explained above, and if it is greater than 3°, compare it to the

DRIVESHAFT	MAXIMUM
5000	3.2°
4500	3.7°
4000	4.2°
3500	5.0°
3000	5.8°
2500	7.0°
2000	8.7°

following chart.

The angles shown on the chart are the MAXIMUM u-joint operating angles recommended by BOSS INDUSTRIES and are directly related to the speed of the driveshaft. Any u-joint operating angle greater than 3° will lower u-joint life and may cause vibration. Remember to check maximum safe driveshaft RPM as recommended by the driveshaft manufacturer.

### ANGLE CHART

FOR DRIVESHAFTS HAVING AN ANGLE IN THE TOP VIEW

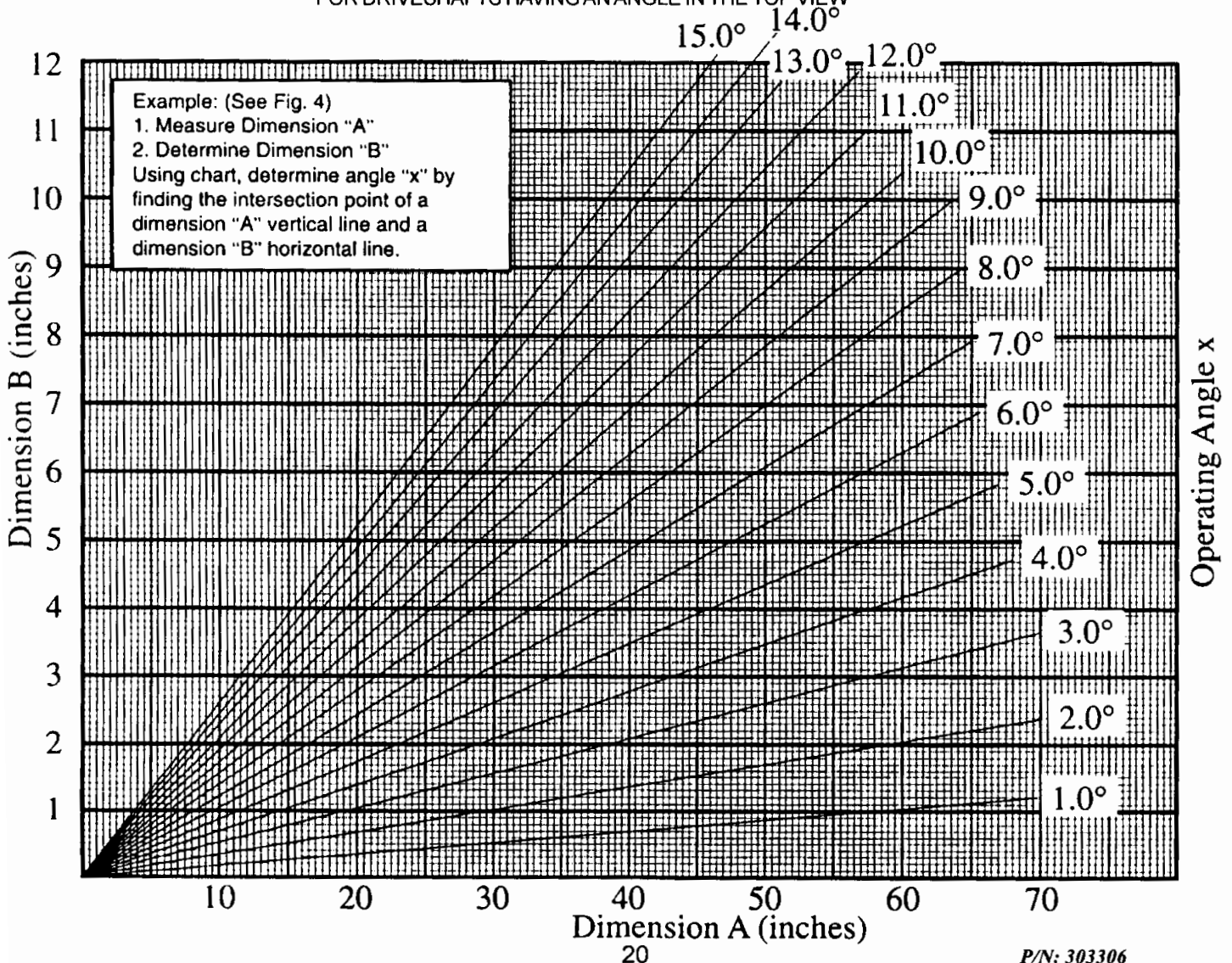

# SIDE VIEW OPERATING ANGLE CALCULATIONS WITH UP HILL SHAFT

## SIDE VIEW OPERATING ANGLE CALCULATIONS WITH UP HILL SHAFT

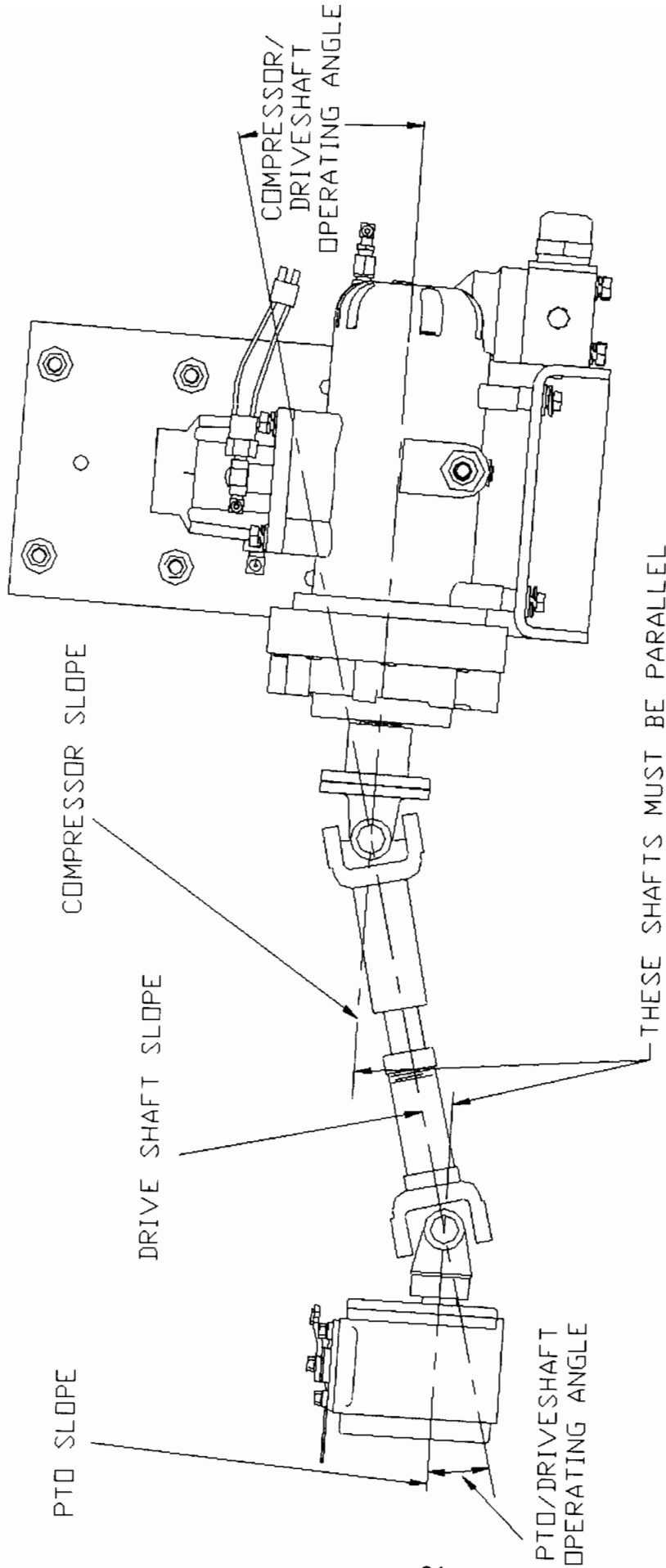

### SIDE VIEW OPERATING ANGLE CALCULATIONS

$$\begin{array}{r}
 \text{PTO SLOPE} \text{ --} \\
 \text{SHAFT SLOPE} \\
 + \\
 \text{DEGREE DOWN} \\
 \text{DEGREE UP} \\
 \text{PTO/DRIVE SHAFT} \\
 \text{OPERATING ANGLE} \\
 = \\
 \text{SHAFT SLOPE} \text{ --} \\
 \text{COMPR. SLOPE} \\
 + \\
 \text{DEGREE UP} \\
 \text{DEGREE DOWN} \\
 \text{PTO/DRIVE SHAFT} \\
 \text{OPERATING ANGLE} \\
 =
 \end{array}$$

OPERATING ANGLES MUST BE WITHIN 1 DEGREE OF EACH OTHER