

BGB GAS ROTARY SCREW SERIES

BGB



- For an efficient and economic production tool that utilizes a separate engine and rotary screw booster, turn to the BGB Gas Booster System from BOSS Industries.
- Small, lightweight, portable packages designed for unattended operation, that can easily be transported and installed from wellhead to wellhead with no site preparation.
- Gas production volumes up to 650 MSCFD and discharge pressures up to 220 PSIG.



BIG ENOUGH TO HANDLE THE TOUGHEST JOBS...

SMALL ENOUGH TO BE VERSATILE AND LIGHT WEIGHT!

BOSS [®] *The Difference is Revolutionary™*

CONTINUOUS POWER FROM THE NAME YOU TRUST

SPECIFICATIONS

STANDARD EQUIPMENT

- Separate Engine/Compressor
- Two-Stage Engine Air Filter
- ASME Compressor Gas/Oil Separation Receiver tank
- Full gauge Panel (Tachometer, Engine Coolant Temperature, Compressor Oil Temperature, Ammeter, Hourmeter, Suction and Discharge Pressure)
- Electronic Governor
- Inlet Gas Scrubber with High Liquid Level Shutdown
- Shutdown Switches (Low Engine Oil Pressure, Low Engine Oil Level, High Coolant Temperature, and Compressor Discharge Temperature, Low Inlet and High Discharge Gas Pressure)
- Manual By-pass Valve
- 5.5 Gallon Engine Oil Make-Up System
- Adjustable Hight Hitch

- 12 Volt DC, Heavy Duty Maintenance Free Battery with Remote Battery Jumper Posts
- Trailer Light Package
- All Vessels Protected by Pressure Relief Valves
- Gas After Cooler (10°F Approach)
- Engine Radiator
- Compressor Oil Cooler
- 1 Year Limited Warranty

AVAILABLE OPTIONS

- ASME Blowcase Scrubber Tank
- Trailer Brakes
- Shutdown Indicators
- Special Paints
- Low Engine Coolant Shutdown
- Automatic Liquid Level Drain on Inlet Scrubber
- Automatic By-Pass Valve
- Oil Field Skid Mounted
- High-Pressure Models Available, up to 220 PSIG



MODEL	BGB 300	BGB 425	BGB 700
Production Volumes	Up to 300 MSCFD	Up to 425 MSCFD	Up to 650 MSCFD
Suction Pressure	0 to 10 PSIG	0 to 10 PSIG	0 to 7 PSIG
Discharge Pressure	Up to 150 PSIG	Up to 220 PSIG	Up to 100 PSIG
Gas End Warranty	1 Year Limited	1 Year Limited	1 Year Limited
Engine Model	GM Vortec 3.0L	GM Vortec 4.3L	GM Vortec 5.7L
Engine HP	42 Continuous	63 Continuous	95 Continuous
Engine Idle RPM	1400	1400	1400
Engine Full Load RPM	2400	2400	2400

ADVANTAGES

- No Site Preparation
- High Performance
- Easy Maintenance
- Low Noise Levels

FOR ALL UNITS CHASSIS:

Dimensions	Length	Width	Height	Weight
BGB 300/425	139.5"	64"	78.25"	2,400 Lbs
BGB 700	153"	64"	81.75"	3,500 Lbs

Gas Connection	Inlet	Discharge
BGB 300/425	3" FNPT	2" FNPT
BGB 700	3" FNPT	2" FNPT

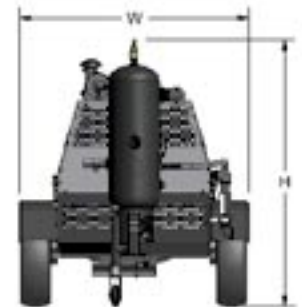

(Subject to change without notice)

BOSS *The Difference is Revolutionary™*

DISTRIBUTED BY:

BOSS INDUSTRIES, INC.

1761 Genesis Drive LaPorte, IN 46350
 Voice: 219.324.7776 • 1.800.635.6587
 Fax: 219.324.7470
 Electronic: www.bossair.com • email: boss@bossair.com